

Machine Learning – Lecture 16

Convolutional Neural Networks II

18.12.2019

Bastian Leibe

RWTH Aachen

<http://www.vision.rwth-aachen.de>

leibe@vision.rwth-aachen.de

Course Outline

- Fundamentals
 - Bayes Decision Theory
 - Probability Density Estimation
- Classification Approaches
 - Linear Discriminants
 - Support Vector Machines
 - Ensemble Methods & Boosting
 - Random Forests
- Deep Learning
 - Foundations
 - Convolutional Neural Networks
 - Recurrent Neural Networks

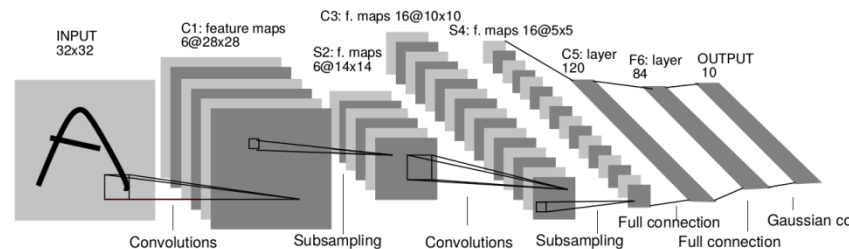
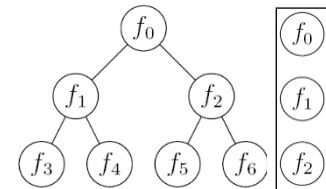
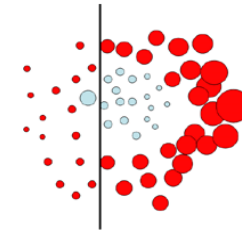
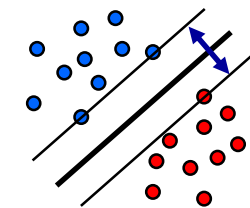
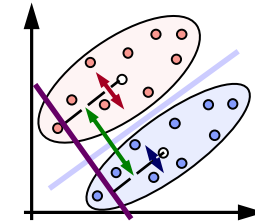
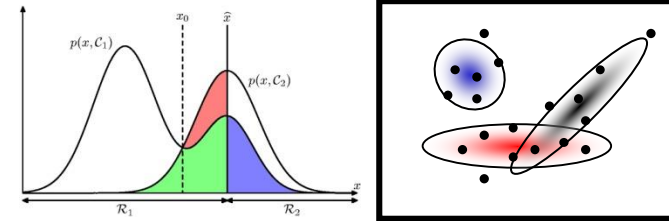

Topics of This Lecture

- Recap: CNNs
- CNN Architectures
 - LeNet
 - AlexNet
 - VGGNet
 - GoogLeNet
 - ResNets
- Visualizing CNNs
 - Visualizing CNN features
 - Visualizing responses
 - Visualizing learned structures
- Applications

Recap: Convolutional Neural Networks

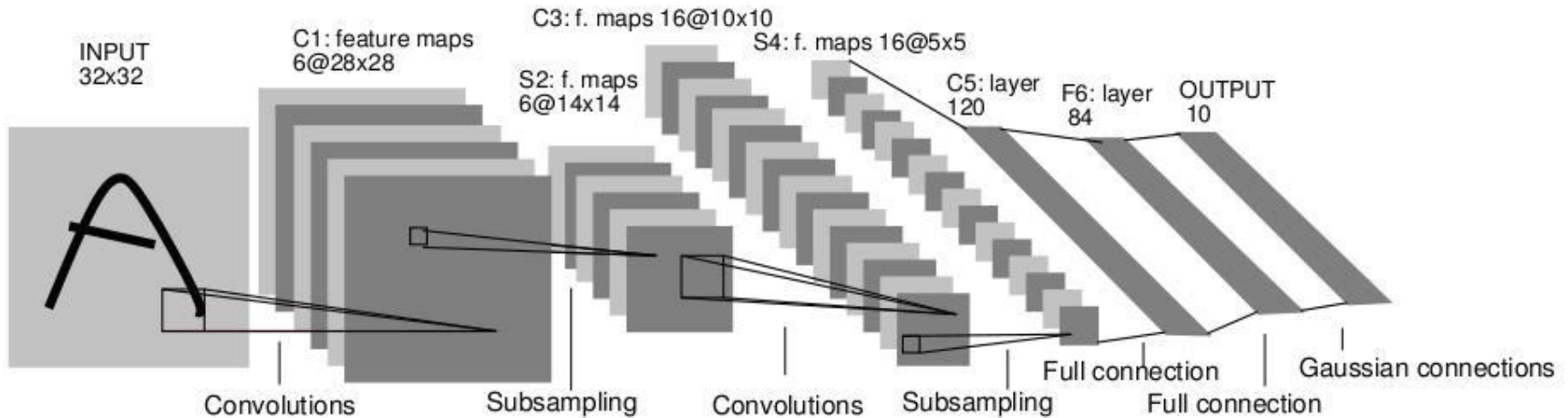

- Neural network with specialized connectivity structure
 - Stack multiple stages of feature extractors
 - Higher stages compute more global, more invariant features
 - Classification layer at the end

Y. LeCun, L. Bottou, Y. Bengio, and P. Haffner, [Gradient-based learning applied to document recognition](#), Proceedings of the IEEE 86(11): 2278–2324, 1998.

Recap: Intuition of CNNs

- Convolutional net

- Share the same parameters across different locations
- Convolutions with learned kernels

- Learn *multiple* filters

- E.g. 1000×1000 image
100 filters
10 \times 10 filter size
 \Rightarrow only 10k parameters

- Result: Response map

- size: $1000 \times 1000 \times 100$
- Only memory, not params!

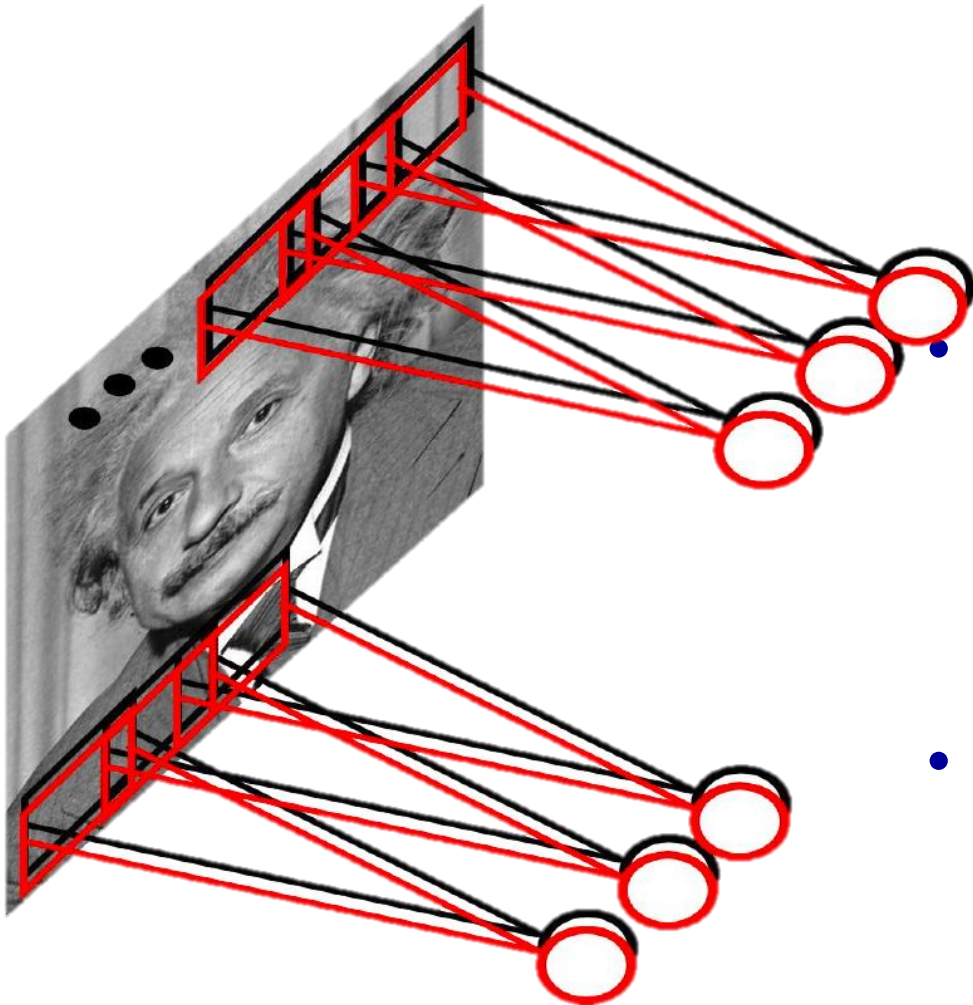

Recap: Convolution Layers

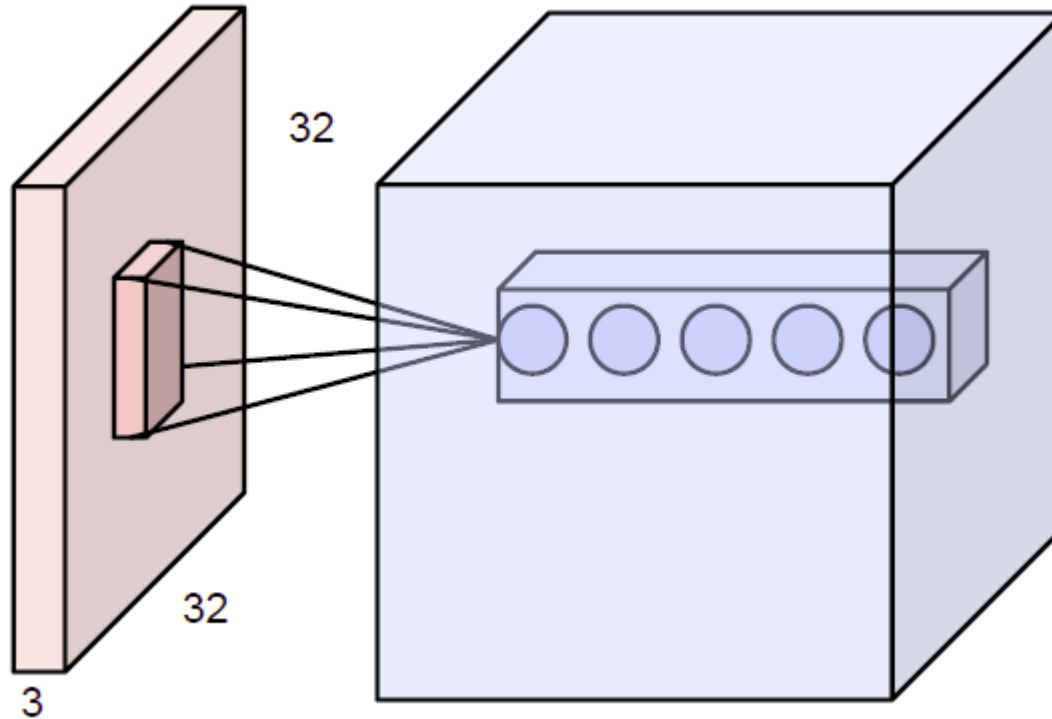

Naming convention:

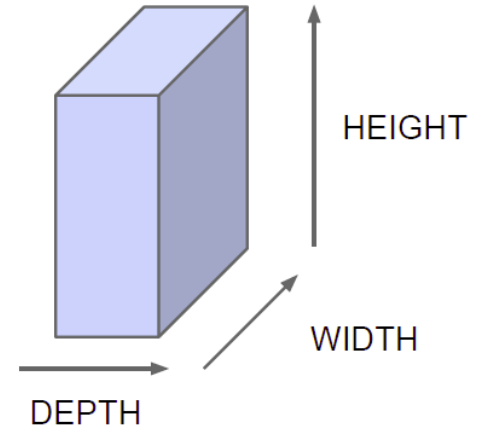

- All Neural Net activations arranged in 3 dimensions
 - Multiple neurons all looking at the same input region, stacked in depth
 - Form a single $[1 \times 1 \times \text{depth}]$ depth column in output volume.

Convolution Layers

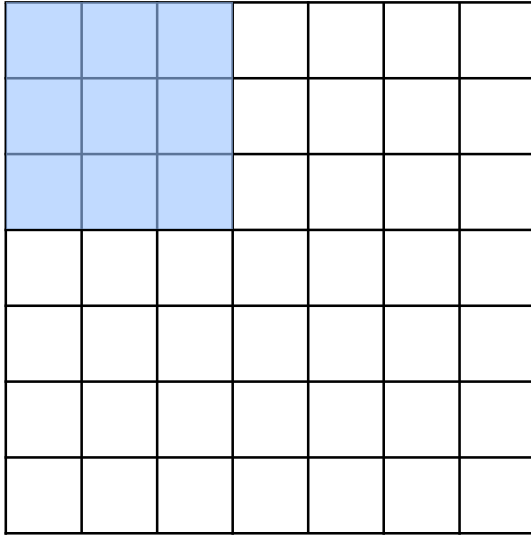

Example:
 7×7 input
assume 3×3 connectivity
stride 1

- Replicate this column of hidden neurons across space, with some **stride**.

Convolution Layers

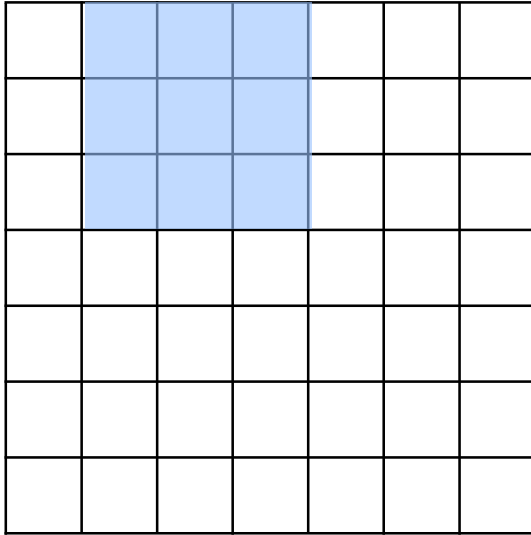

Example:
 7×7 input
assume 3×3 connectivity
stride 1

- Replicate this column of hidden neurons across space, with some **stride**.

Convolution Layers

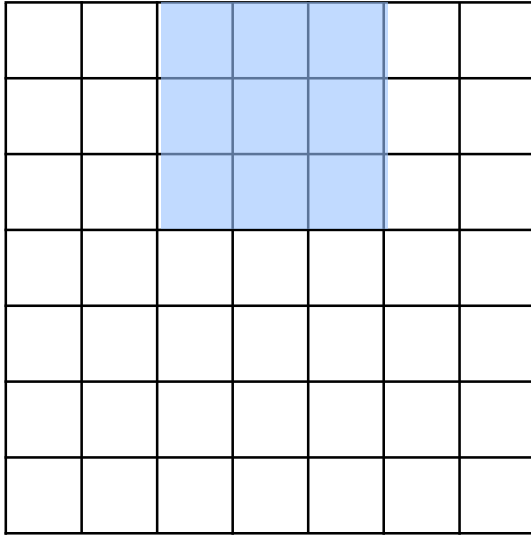

Example:
 7×7 input
assume 3×3 connectivity
stride 1

- Replicate this column of hidden neurons across space, with some **stride**.

Convolution Layers

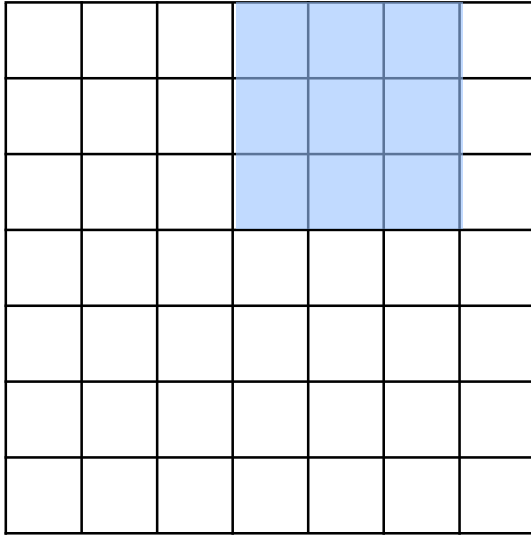

Example:
 7×7 input
assume 3×3 connectivity
stride 1

- Replicate this column of hidden neurons across space, with some **stride**.

Convolution Layers

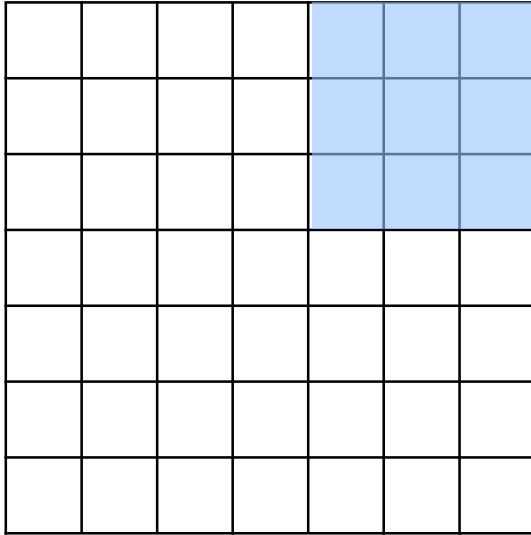

Example:
 7×7 input
assume 3×3 connectivity
stride 1
 $\Rightarrow 5 \times 5$ output

- Replicate this column of hidden neurons across space, with some **stride**.

Convolution Layers

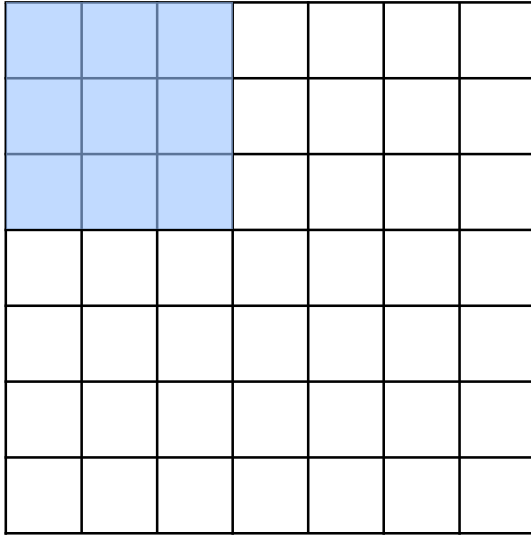

Example:

7×7 input

assume 3×3 connectivity

stride 1

$\Rightarrow 5 \times 5$ output

What about stride 2?

- Replicate this column of hidden neurons across space, with some **stride**.

Convolution Layers

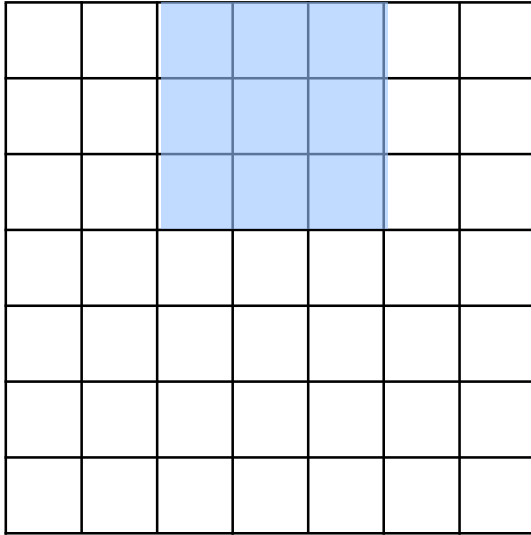

Example:

7×7 input

assume 3×3 connectivity

stride 1

$\Rightarrow 5 \times 5$ output

What about stride 2?

- Replicate this column of hidden neurons across space, with some **stride**.

Convolution Layers

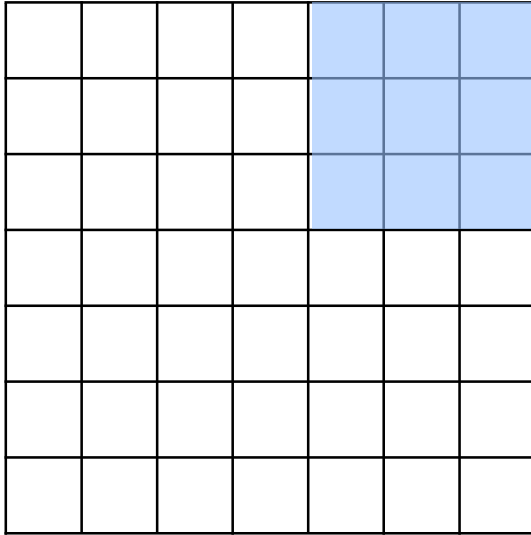

Example:

7×7 input

assume 3×3 connectivity

stride 1

$\Rightarrow 5 \times 5$ output

What about stride 2?

$\Rightarrow 3 \times 3$ output

- Replicate this column of hidden neurons across space, with some **stride**.

Convolution Layers

0	0	0	0	0				
0								
0								
0								
0								

Example:

7×7 input

assume 3×3 connectivity

stride 1

$\Rightarrow 5 \times 5$ output

What about stride 2?

$\Rightarrow 3 \times 3$ output

- Replicate this column of hidden neurons across space, with some **stride**.
- In practice, common to zero-pad the border.
 - Preserves the size of the input spatially.

Activation Maps of Convolutional Filters

Activations:



one filter = one depth slice (or activation map)

5 × 5 filters

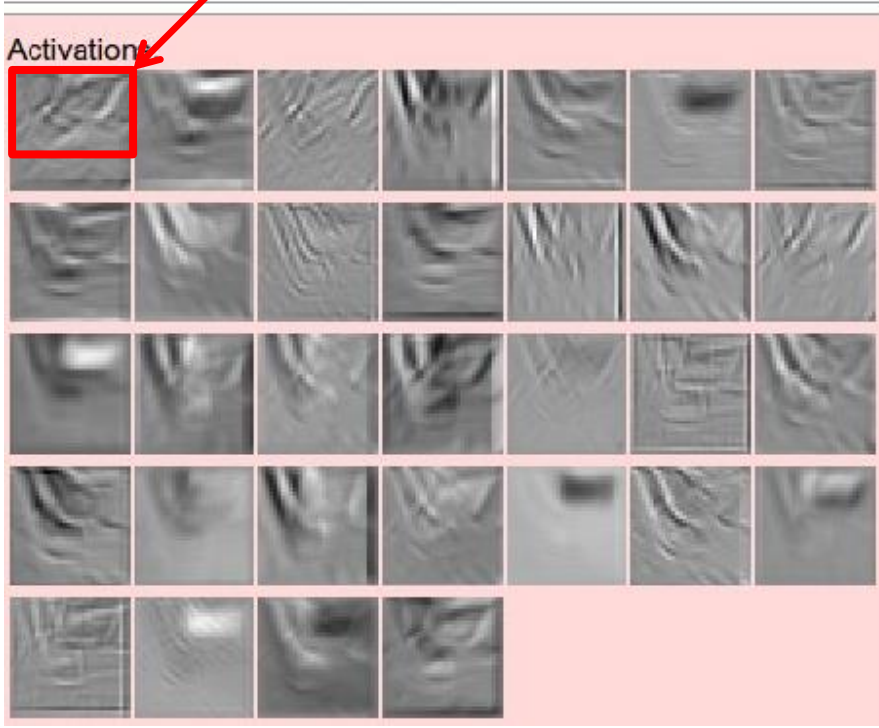

Activation maps

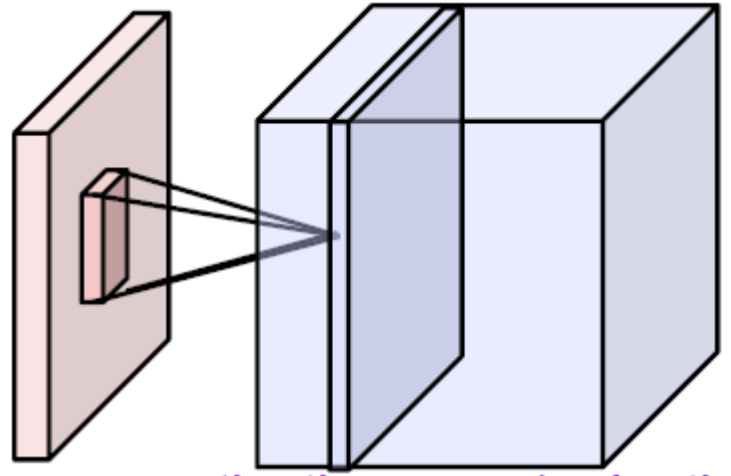

Each activation map is a depth slice through the output volume.

Effect of Multiple Convolution Layers

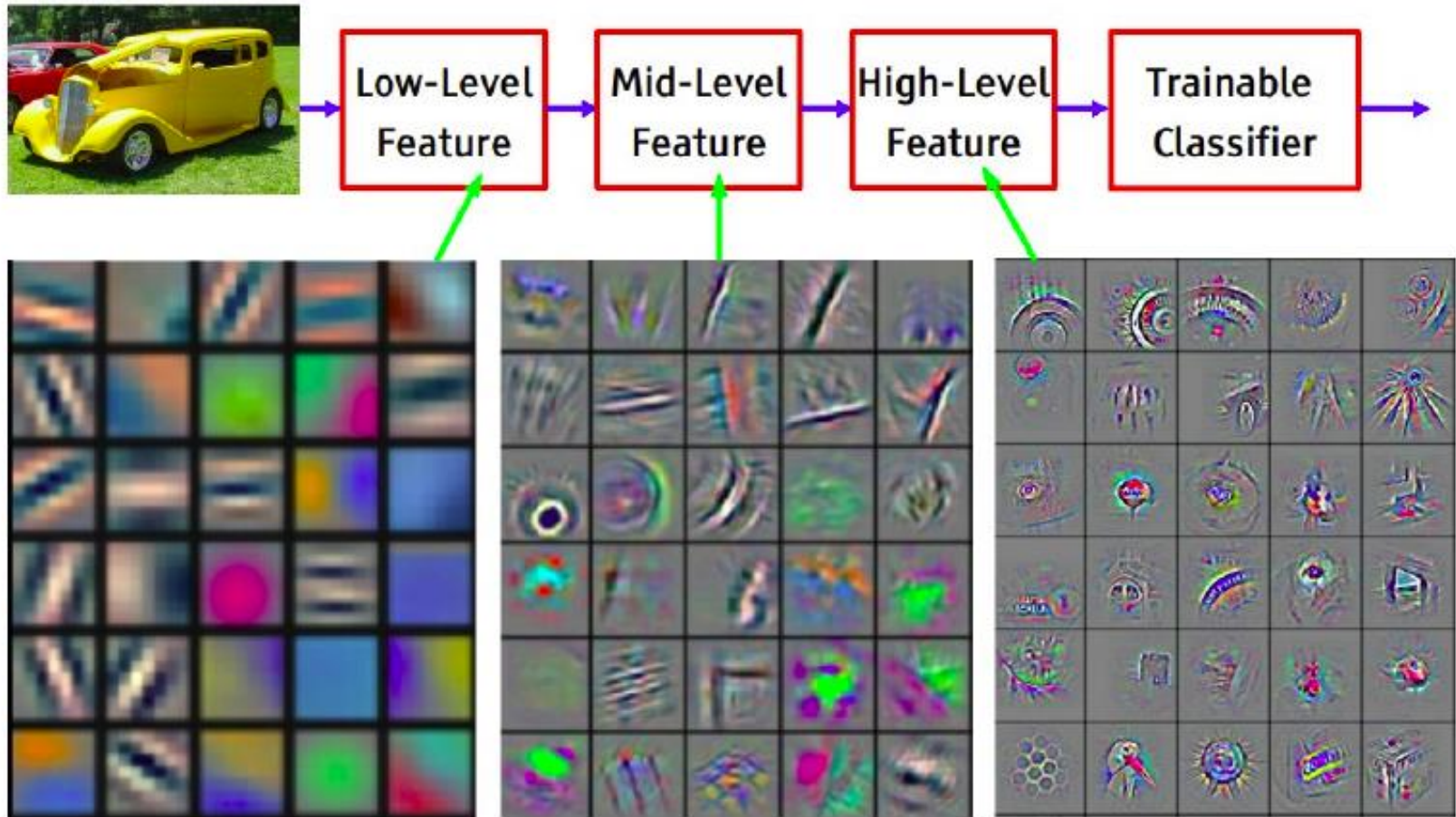

Feature visualization of convolutional net trained on ImageNet from [Zeiler & Fergus 2013]

Convolutional Networks: Intuition

- Let's assume the filter is an eye detector
 - How can we make the detection robust to the exact location of the eye?

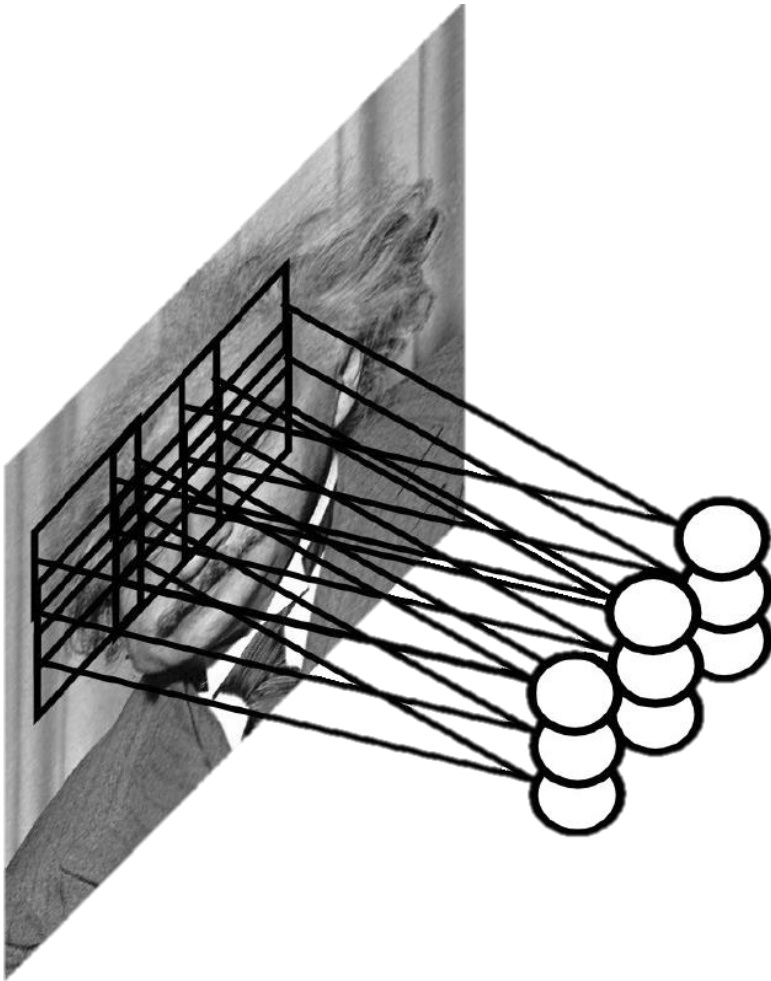

Convolutional Networks: Intuition

- Let's assume the filter is an eye detector
 - How can we make the detection robust to the exact location of the eye?
- Solution:
 - By **pooling** (e.g., max or avg) filter responses at different spatial locations, we gain robustness to the exact spatial location of features.

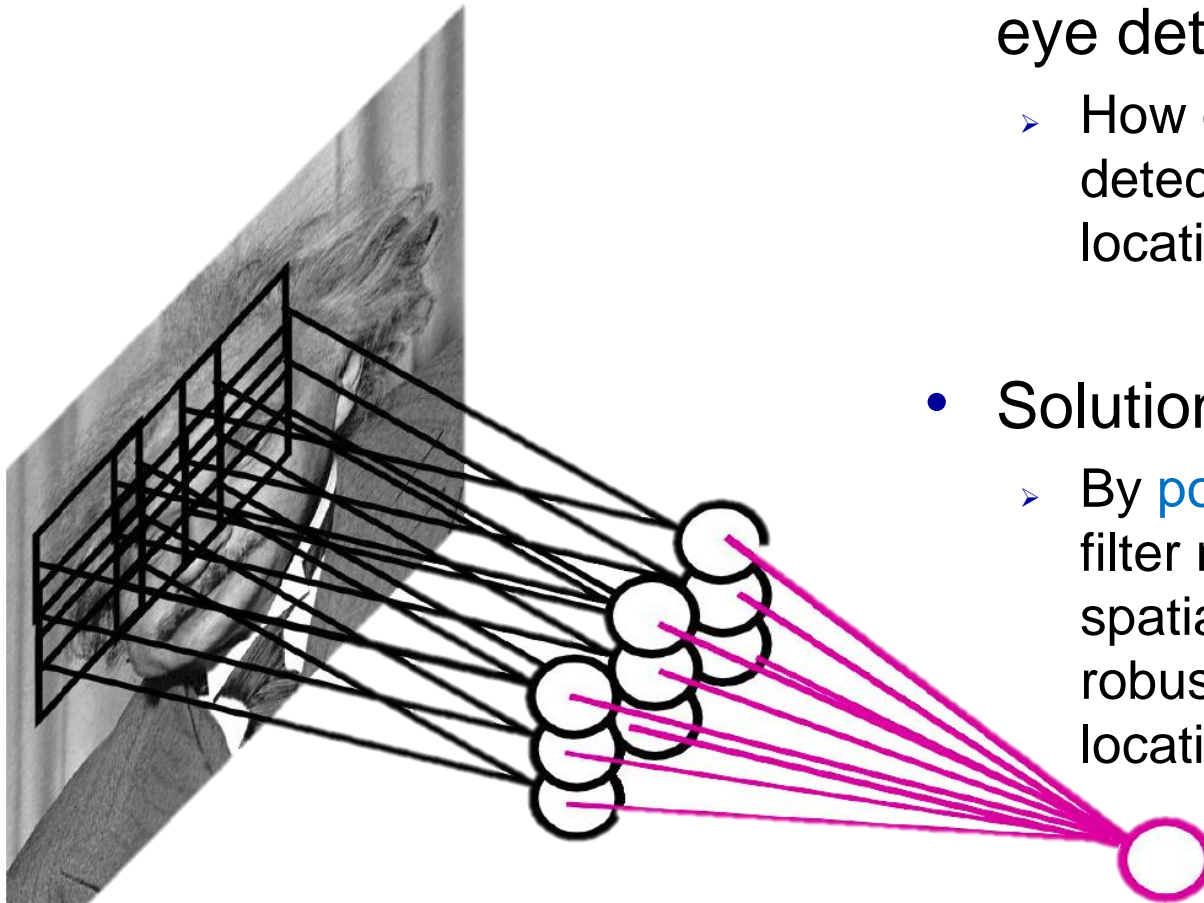

Max Pooling

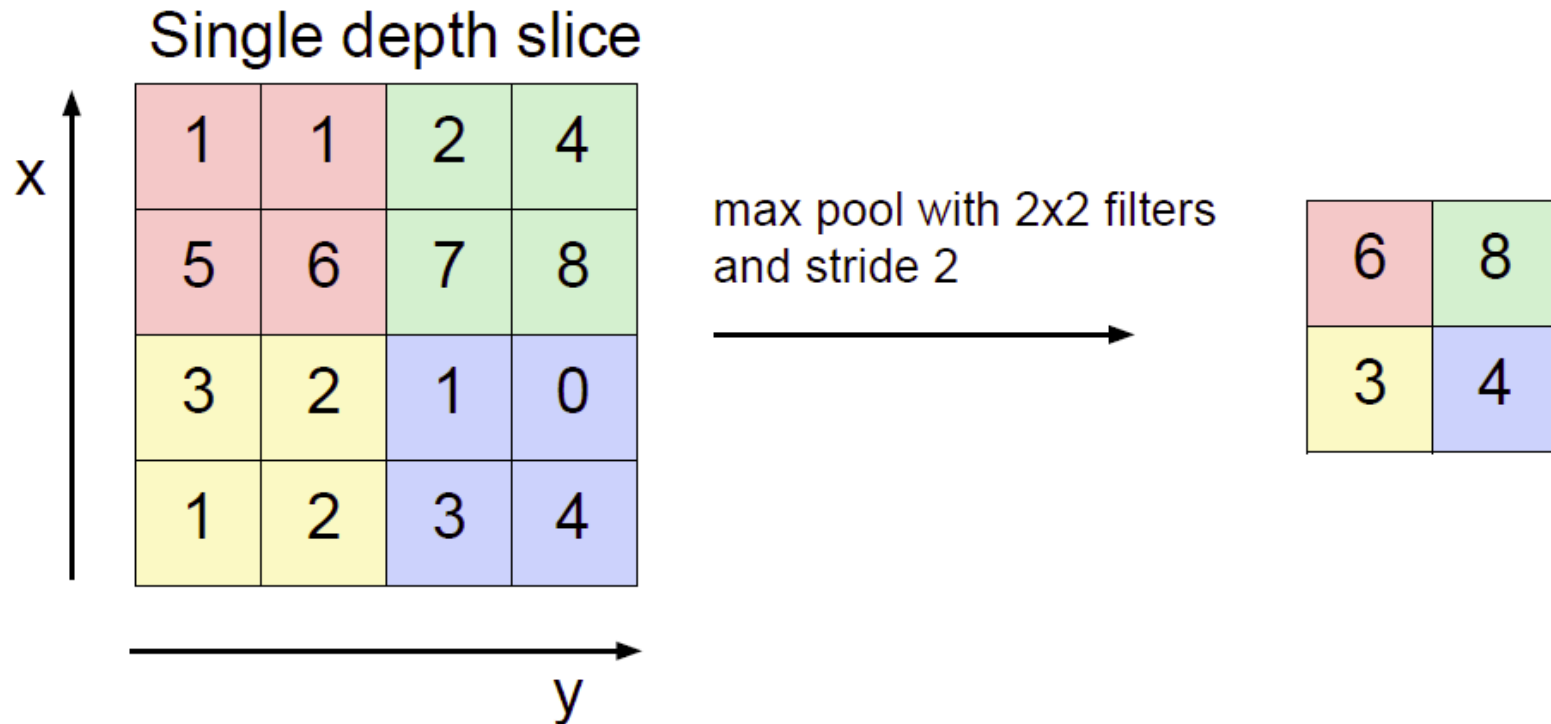

- Effect:
 - Make the representation smaller without losing too much information
 - Achieve robustness to translations

Max Pooling

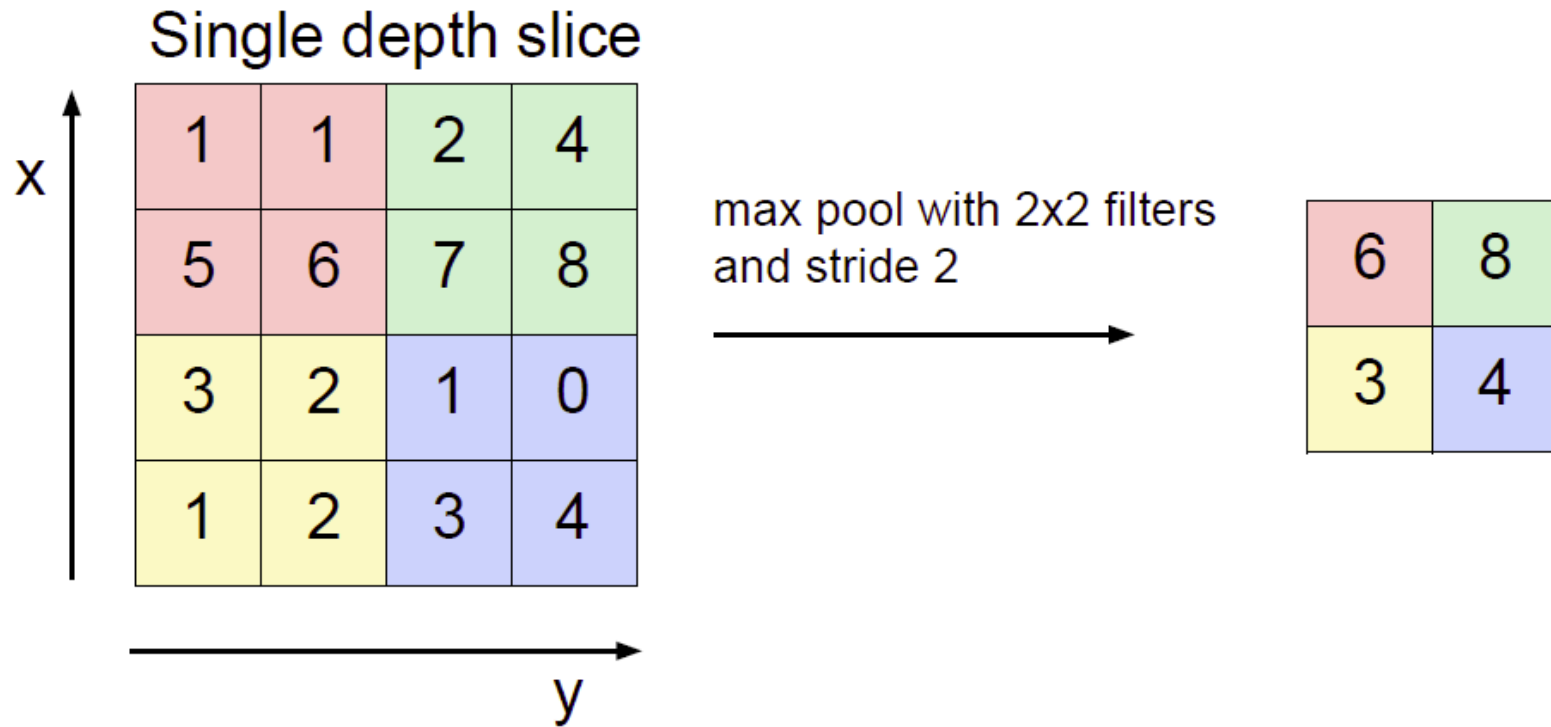

- Note

- Pooling happens independently across each slice, preserving the number of slices.

CNNs: Implication for Back-Propagation

- Convolutional layers
 - Filter weights are shared between locations
 - ⇒ Gradients are added for each filter location.

Topics of This Lecture

- Recap: CNNs
- CNN Architectures
 - LeNet
 - AlexNet
 - VGGNet
 - GoogLeNet
 - ResNet
- Visualizing CNNs
 - Visualizing CNN features
 - Visualizing responses
 - Visualizing learned structures
- Applications

CNN Architectures: LeNet (1998)

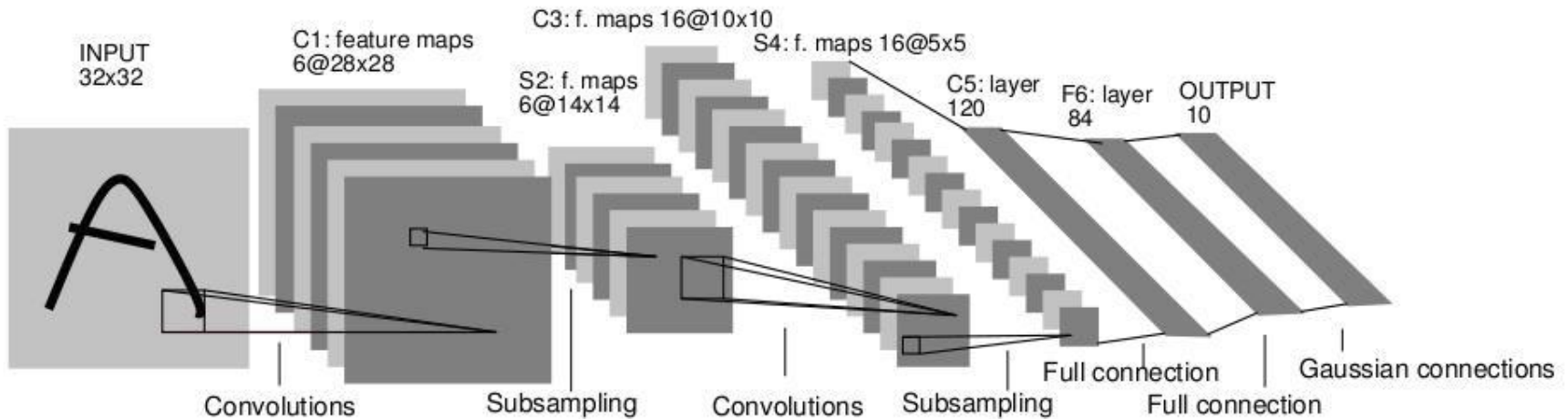

- Early convolutional architecture
 - 2 Convolutional layers, 2 pooling layers
 - Fully-connected NN layers for classification
 - Successfully used for handwritten digit recognition (MNIST)

Y. LeCun, L. Bottou, Y. Bengio, and P. Haffner, [Gradient-based learning applied to document recognition](#), Proceedings of the IEEE 86(11): 2278–2324, 1998.

ImageNet Challenge 2012

- ImageNet

- ~14M labeled internet images
- 20k classes
- Human labels via Amazon Mechanical Turk

IM  GENET

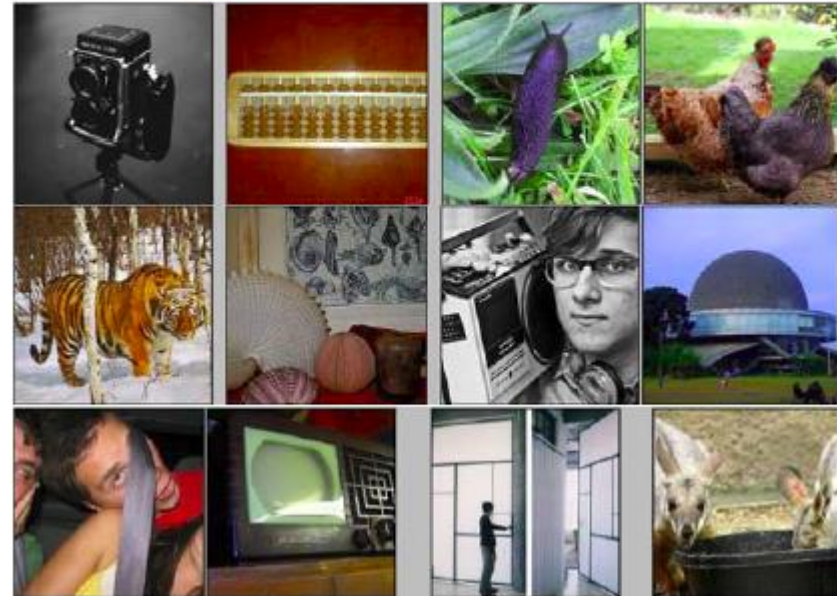

[Deng et al., CVPR'09]

- Challenge (ILSVRC)

- 1.2 million training images
- 1000 classes
- Goal: Predict ground-truth class within top-5 responses
- Currently one of the top benchmarks in Computer Vision

CNN Architectures: AlexNet (2012)

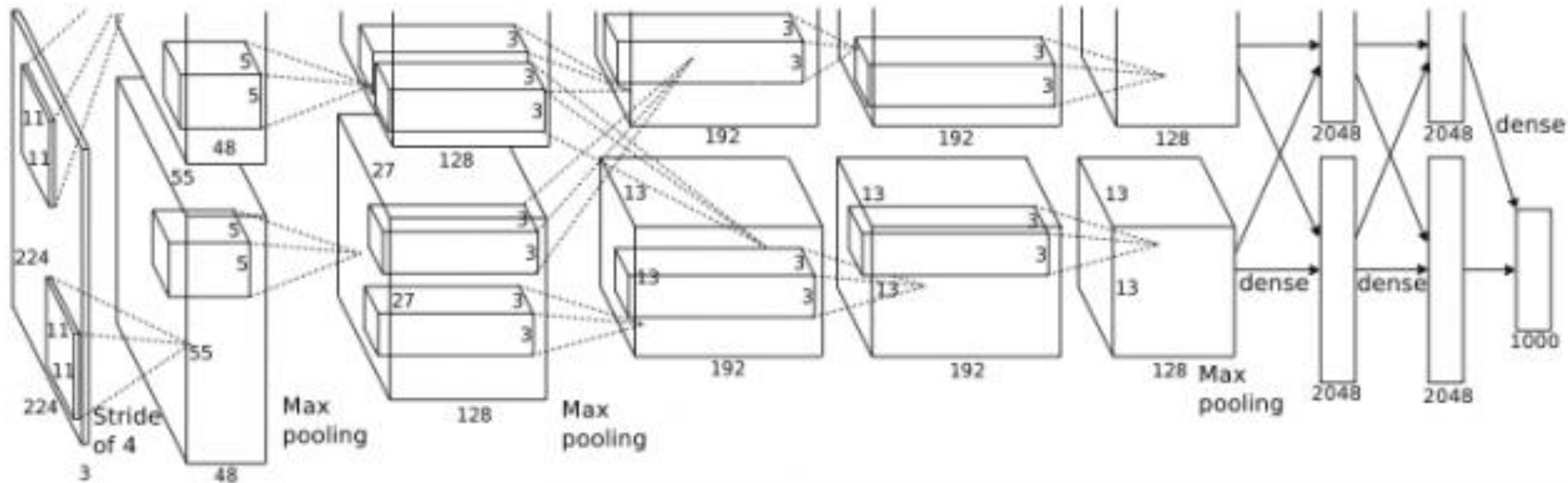

- Similar framework as LeNet, but
 - Bigger model (7 hidden layers, 650k units, 60M parameters)
 - More data (10^6 images instead of 10^3)
 - GPU implementation
 - Better regularization and up-to-date tricks for training (Dropout)

A. Krizhevsky, I. Sutskever, and G. Hinton, [ImageNet Classification with Deep Convolutional Neural Networks](#), NIPS 2012.

ILSVRC 2012 Results

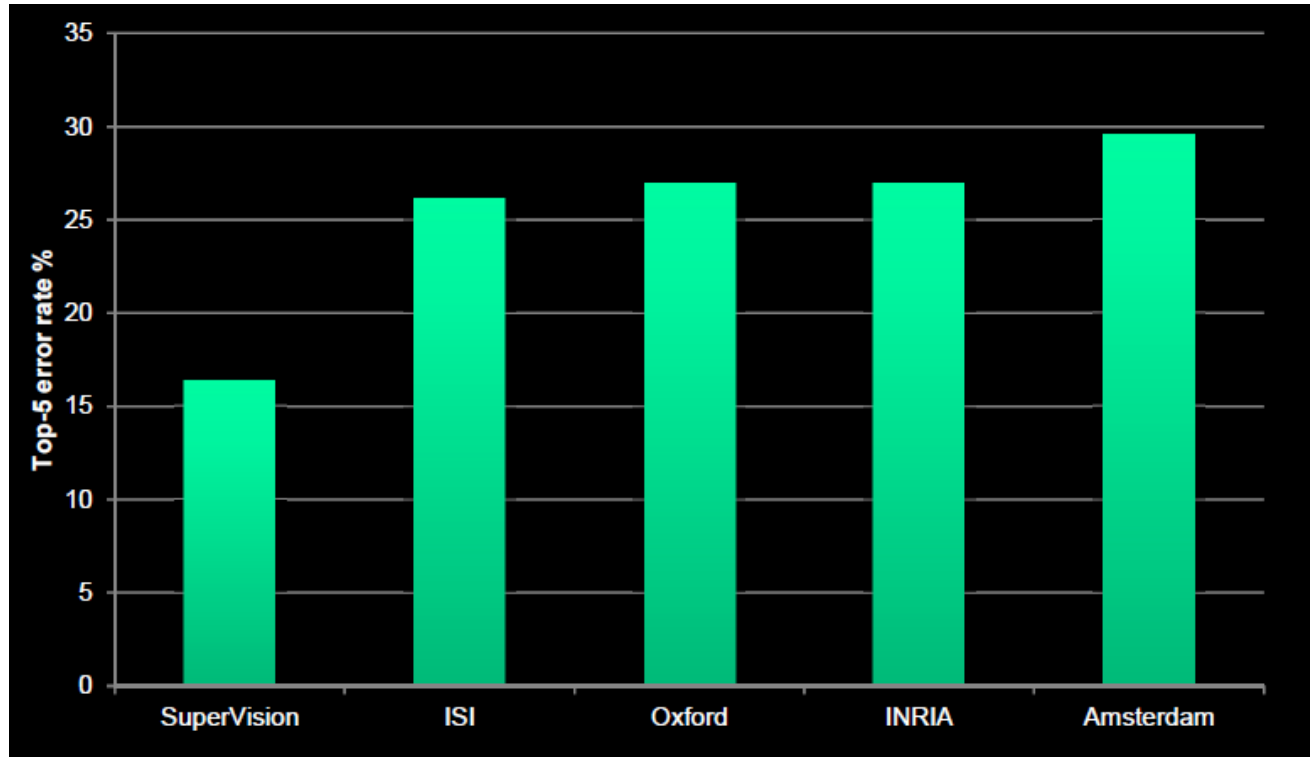

- AlexNet almost halved the error rate
 - 16.4% error (top-5) vs. 26.2% for the next best approach
 - ⇒ A revolution in Computer Vision
 - Acquired by Google in Jan '13, deployed in Google+ in May '13

CNN Architectures: VGGNet (2014/15)

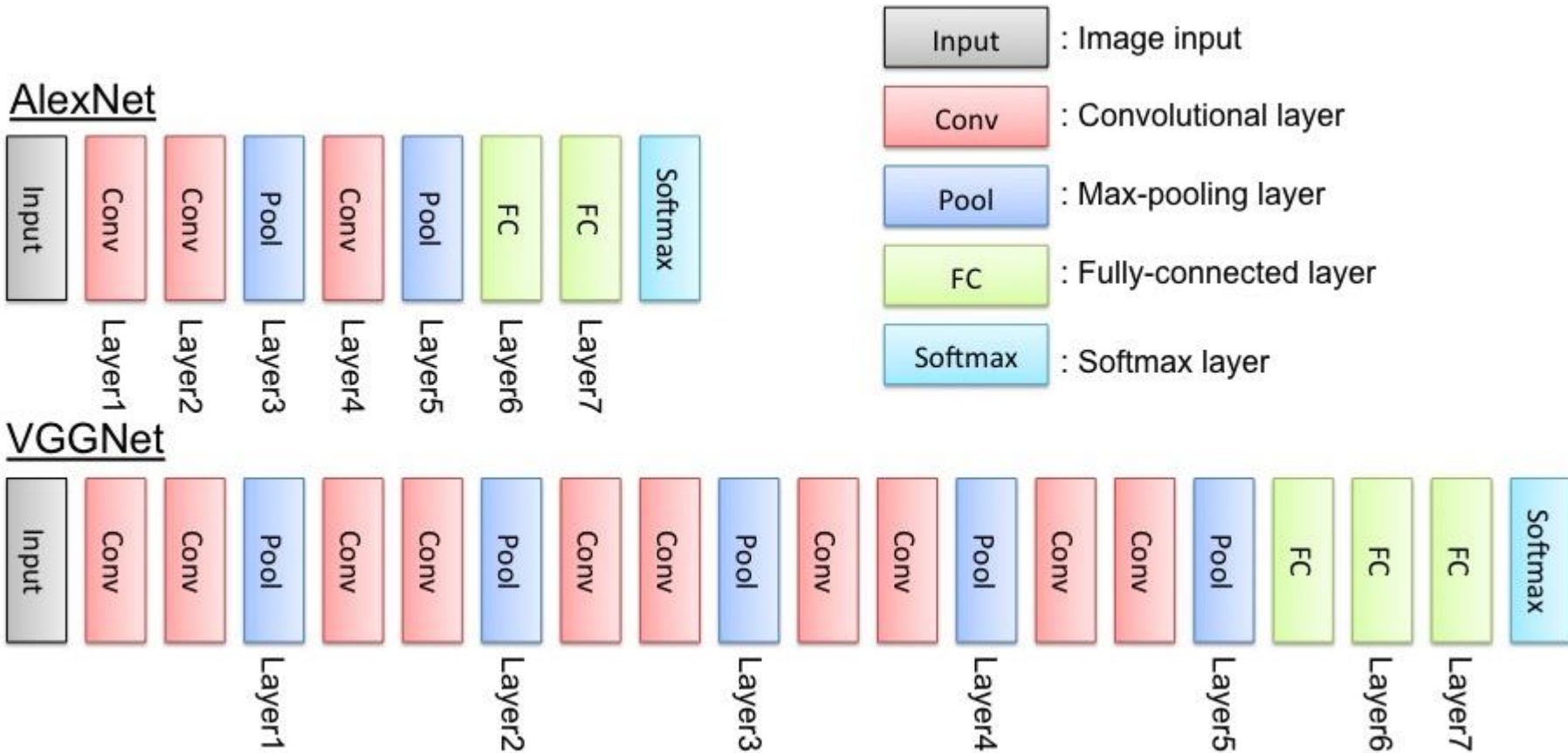

K. Simonyan, A. Zisserman, [Very Deep Convolutional Networks for Large-Scale Image Recognition](#), ICLR 2015

CNN Architectures: VGGNet (2014/15)

- Main ideas

- Deeper network
- Stacked convolutional layers with smaller filters (+ nonlinearity)
- Detailed evaluation of all components

- Results

- Improved ILSVRC top-5 error rate to 6.7%.

ConvNet Configuration					
A	A-LRN	B	C	D	E
11 weight layers	11 weight layers	13 weight layers	16 weight layers	16 weight layers	19 weight layers
input (224 × 224 RGB image)					
conv3-64	conv3-64 LRN	conv3-64 conv3-64	conv3-64 conv3-64	conv3-64 conv3-64	conv3-64 conv3-64
maxpool					
conv3-128	conv3-128	conv3-128 conv3-128	conv3-128 conv3-128	conv3-128 conv3-128	conv3-128 conv3-128
maxpool					
conv3-256 conv3-256	conv3-256 conv3-256	conv3-256 conv3-256	conv3-256 conv3-256 conv1-256	conv3-256 conv3-256 conv3-256	conv3-256 conv3-256 conv3-256 conv3-256
maxpool					
conv3-512 conv3-512	conv3-512 conv3-512	conv3-512 conv3-512	conv3-512 conv3-512 conv1-512	conv3-512 conv3-512 conv3-512	conv3-512 conv3-512 conv3-512 conv3-512
maxpool					
conv3-512 conv3-512	conv3-512 conv3-512	conv3-512 conv3-512	conv3-512 conv3-512 conv1-512	conv3-512 conv3-512 conv3-512	conv3-512 conv3-512 conv3-512 conv3-512
maxpool					
FC-4096					
FC-4096					
FC-1000					
soft-max					

Mainly used

Comparison: AlexNet vs. VGGNet

- Receptive fields in the first layer
 - AlexNet: 11×11 , stride 4
 - Zeiler & Fergus: 7×7 , stride 2
 - VGGNet: 3×3 , stride 1
- Why that?
 - If you stack a 3×3 on top of another 3×3 layer, you effectively get a 5×5 receptive field.
 - With three 3×3 layers, the receptive field is already 7×7 .
 - But much fewer parameters: $3 \cdot 3^2 = 27$ instead of $7^2 = 49$.
 - In addition, non-linearities in-between 3×3 layers for additional discriminativity.

CNN Architectures: GoogLeNet (2014/2015)

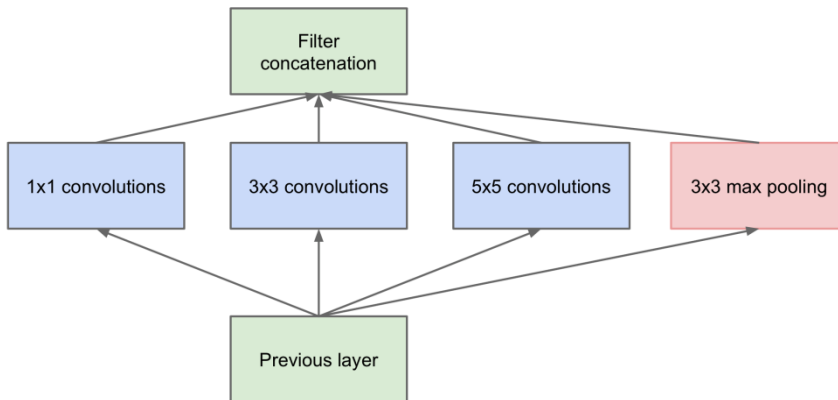

(a) Inception module, naïve version

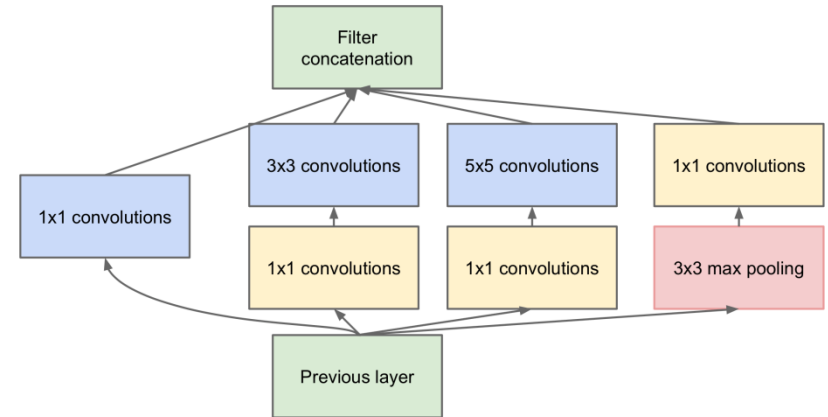

(b) Inception module with dimension reductions

- Main ideas

- “Inception” module as modular component
- Learns filters at several scales within each module

C. Szegedy, W. Liu, Y. Jia, et al, [Going Deeper with Convolutions](#), arXiv:1409.4842, 2014, CVPR'15, 2015.

GoogLeNet Visualization

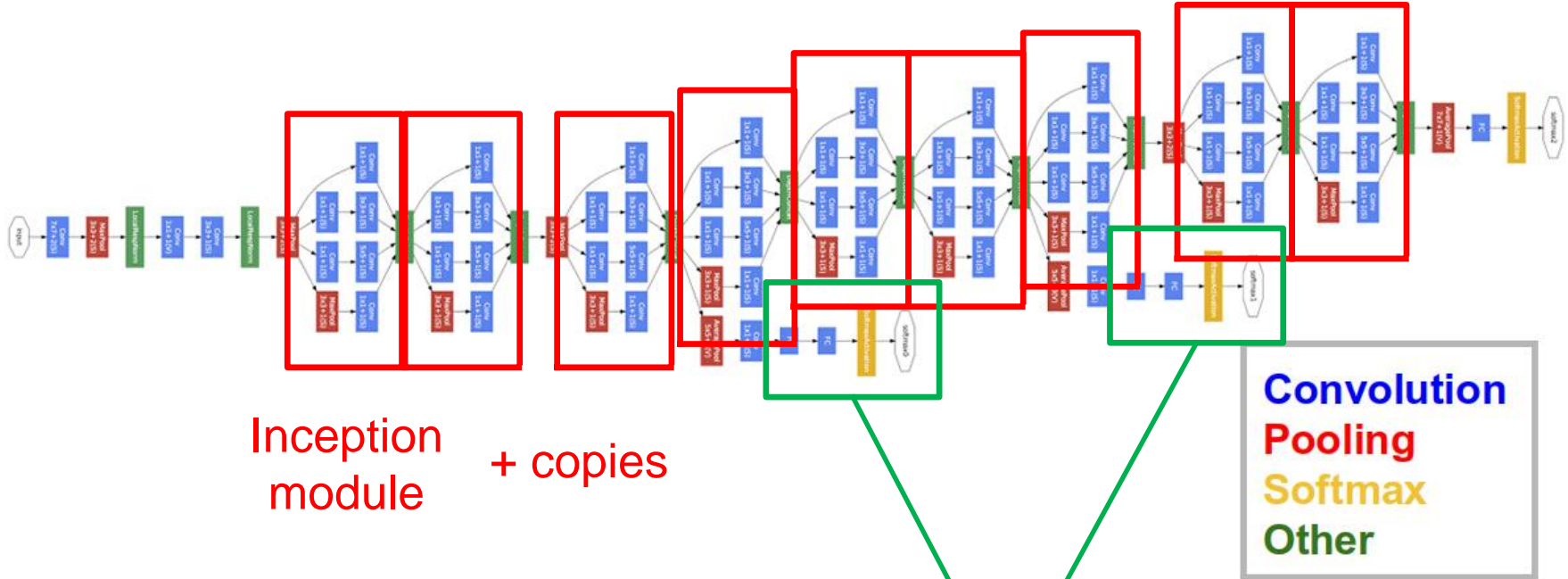

Inception module + copies

Convolution
Pooling
Softmax
Other

Auxiliary classification outputs for training the lower layers (deprecated)

Results on ILSVRC

Method	top-1 val. error (%)	top-5 val. error (%)	top-5 test error (%)
VGG (2 nets, multi-crop & dense eval.)	23.7	6.8	6.8
VGG (1 net, multi-crop & dense eval.)	24.4	7.1	7.0
VGG (ILSVRC submission, 7 nets, dense eval.)	24.7	7.5	7.3
GoogLeNet (Szegedy et al., 2014) (1 net)	-	7.9	
GoogLeNet (Szegedy et al., 2014) (7 nets)	-	6.7	
MSRA (He et al., 2014) (11 nets)	-	-	8.1
MSRA (He et al., 2014) (1 net)	27.9	9.1	9.1
Clarifai (Russakovsky et al., 2014) (multiple nets)	-	-	11.7
Clarifai (Russakovsky et al., 2014) (1 net)	-	-	12.5
Zeiler & Fergus (Zeiler & Fergus, 2013) (6 nets)	36.0	14.7	14.8
Zeiler & Fergus (Zeiler & Fergus, 2013) (1 net)	37.5	16.0	16.1
OverFeat (Sermanet et al., 2014) (7 nets)	34.0	13.2	13.6
OverFeat (Sermanet et al., 2014) (1 net)	35.7	14.2	-
Krizhevsky et al. (Krizhevsky et al., 2012) (5 nets)	38.1	16.4	16.4
Krizhevsky et al. (Krizhevsky et al., 2012) (1 net)	40.7	18.2	-

- VGGNet and GoogLeNet perform at similar level
 - Comparison: human performance ~5% [Karpathy]

<http://karpathy.github.io/2014/09/02/what-i-learned-from-competing-against-a-convnet-on-imagenet/>

Newer Developments: Residual Networks

AlexNet, 8 layers
(ILSVRC 2012)

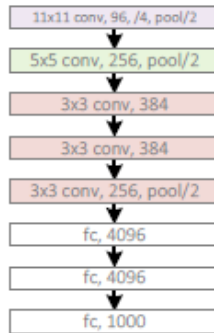

VGG, 19 layers
(ILSVRC 2014)

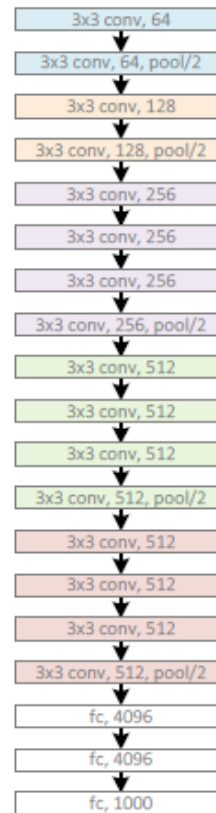

GoogleNet, 22 layers
(ILSVRC 2014)



Newer Developments: Residual Networks

AlexNet, 8 layers
(ILSVRC 2012)



VGG, 19 layers
(ILSVRC 2014)



ResNet, 152 layers
(ILSVRC 2015)

- Core component

- Skip connections bypassing each layer
- Better propagation of gradients to the deeper layers
- We'll analyze this mechanism in more detail later...

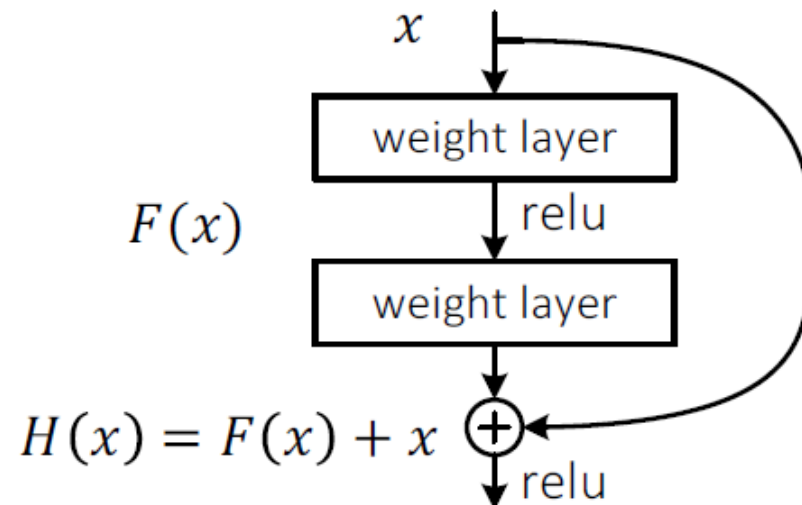

ImageNet Performance

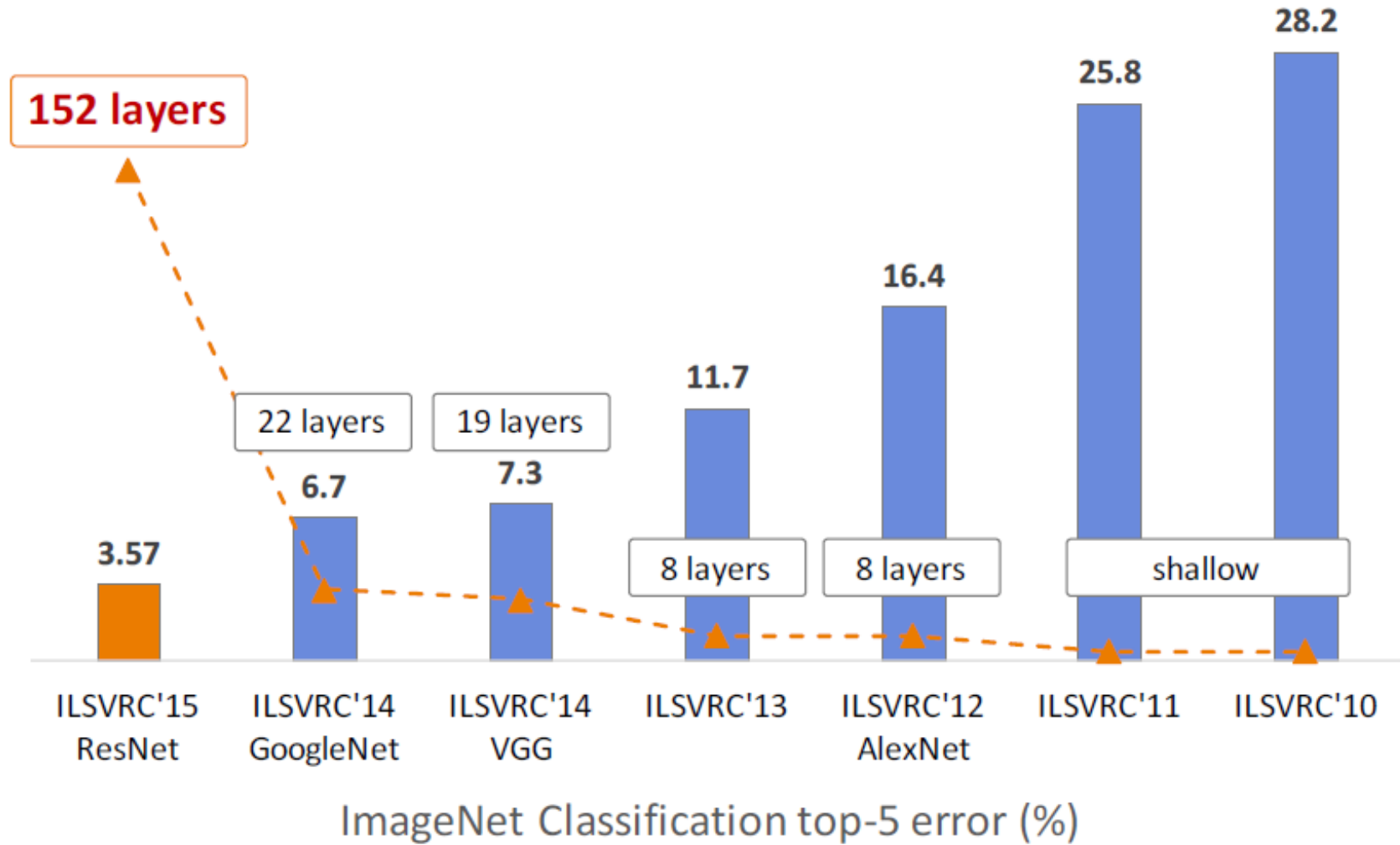

ILSRVC Winners

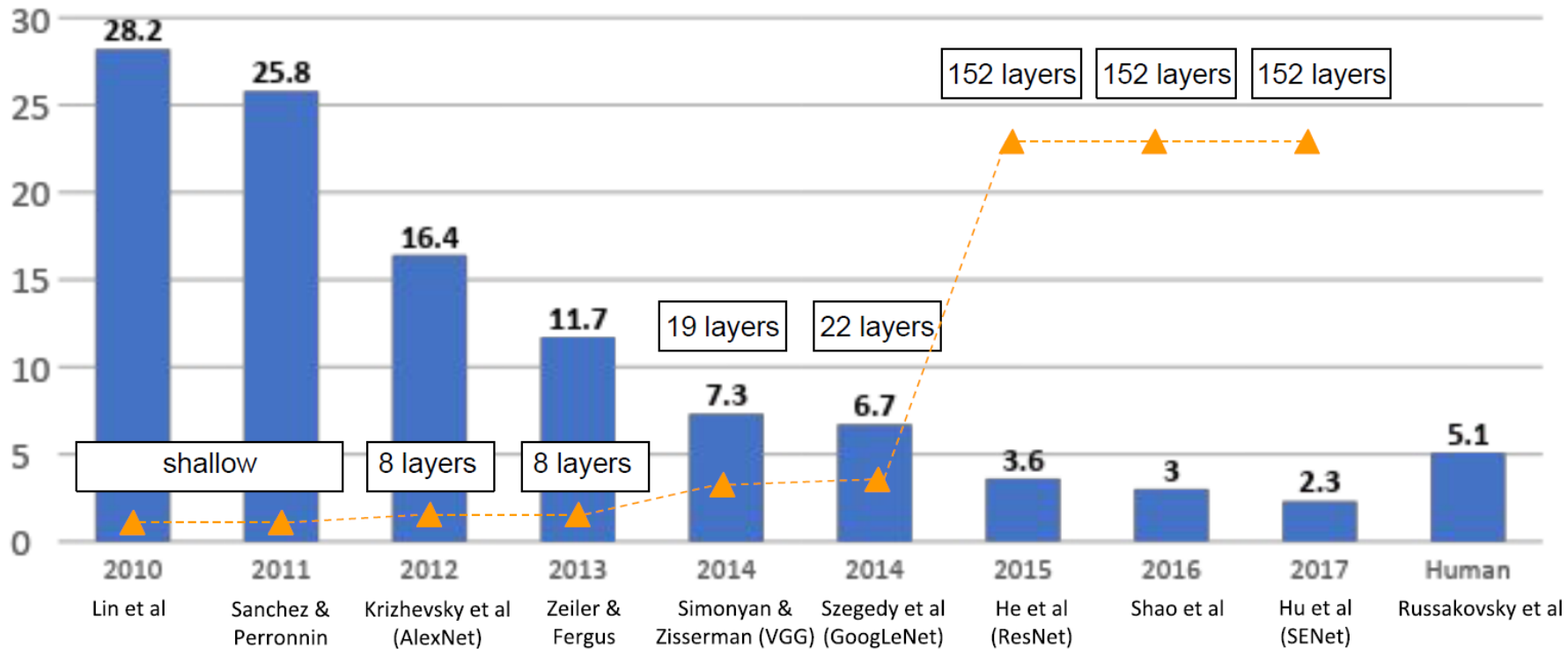

Comparing Complexity

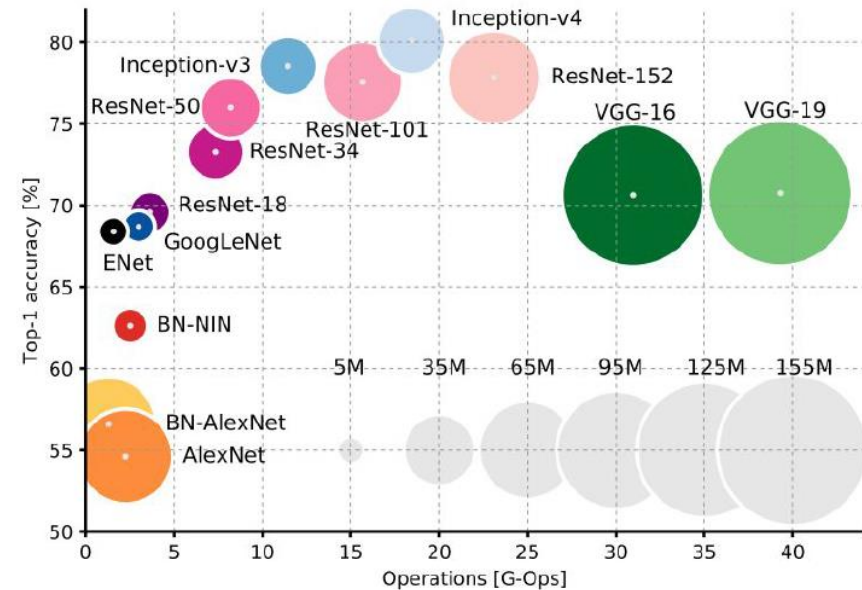
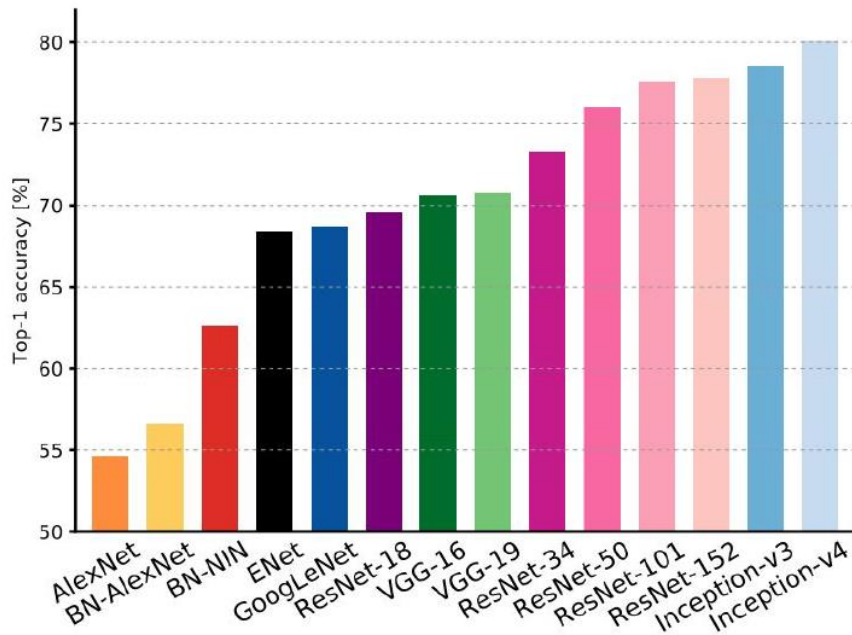

A. Canziano, A. Paszke, E. Culurcello, [An Analysis of Deep Neural Network Models for Practical Applications](#), arXiv 2017.

Understanding the ILSVRC Challenge

- Imagine the scope of the problem!
 - 1000 categories
 - 1.2M training images
 - 50k validation images
- This means...
 - Speaking out the list of category names at 1 word/s...
...takes 15mins.
 - Watching a slideshow of the validation images at 2s/image...
...takes a full day (24h+).
 - Watching a slideshow of the training images at 2s/image...
...takes a full month.

IM  GENET

rind, Alredale, airliner, airship, albatross, alligator lizard, alp, altar, ambulance, American alligator, American black bear, American chameleon, American coot, American egret, American lobster, American Staffordshire terrier, amphibian, analog clock, anemone fish, Angora, ant, apiary, Appenzeller, apron, Arabian camel, Arctic fox, armadillo, artichoke, ashcan, assault rifle, Australian terrier, axolotl, baboon, backpack, badger, bagel, bakery, balance beam, bald eagle, balloon, ballplayer, ballpoint, banana, Band Aid, banded gecko, banjo, bannister, barbell, barber chair, barbershop, barn, barn spider, barometer, barracouta, barrel, barrow, baseball, basenji, basketball, basset, bassinet, bassoon, bath towel, bathing cap, bathtub, beach wagon, beacon, beagle, beaker, bearskin, beaver, Bedlington terrier, bee, bee eater, beer bottle, beer glass, bell cote, bell pepper, Bernese mountain dog, bib, bicycle-built-for-two, bighorn, bikini, binder, binoculars, birdhouse, bison, bittern, black and gold garden spider, black grouse, black stork, black swan, black widow, black-and-tan coonhound, black-footed ferret, Blenheim spaniel, bloodhound, bluetick, boa constrictor, boathouse, bobsled, bolete, bolo tie, bonnet, book jacket, bookcase, bookshop, Border collie, Border terrier, borzoi, Boston bull, bottlecap, Bouvier des Flandres, bow, bow tie, box turtle, boxer, Brabancon griffon, brain coral, brambling, brass, brassiere, breakwater, breastplate, briard, Brittany spaniel, broccoli, broom, brown bear, bubble, bucket, buckeye, buckle, bulbul, bull mastiff, bullet train, bulletproof vest, bullfrog, burrito, bustard, butcher shop, butternut squash, cab, cabbage butterfly, cairn, caldron, can opener, candle, cannon, canoe, capuchin, car mirror, car wheel, carbonara, Cardigan, cardigan, cardoon, carousel, carpenter's kit, carton, cash machine, cassette, cassette player, castle, catamaran, cauliflower, CD player, cello, cellular telephone, centipede, chain, chain mail, chain saw, chain-link fence, chambered nautilus, cheeseburger, cheetah, Chesapeake Bay retriever, chest, chickadee, chiffonier, Chihuahua, chime, chimpanzee, china cabinet, chiton, chocolate sauce, chow, Christmas stocking, church, cicada, cinema, cleaver, cliff, cliff dwelling, cloak, clog, clumber, cock, cocker spaniel, cockroach, cocktail shaker, coffee mug, coffeepot, coho, coil, collie, colobus, combination lock, comic book, common iguana, common newt, computer keyboard, conch, confectionery, consomme, container ship, convertible, coral fungus, coral reef, corkscrew, corn, cornet, coucal, cougar, cowboy boot, cowboy hat, coyote, cradle, crane, crane, crash helmet, crate, crayfish, crib, cricket, Crock Pot, croquet ball, crossword puzzle, crutch, cucumber, cuirass, cup, curly-coated retriever, custard apple, daisy, dalmatian, dam, damselfly, Dandie Dinmont, desk, desktop computer, dhole, dial telephone, diamondback, diaper, digital clock, digital watch, dingo, dining table, dishrag, dishwasher, disk brake, Doberman, dock, dogsled, dome, doormat, dough, dowitcher, dragonfly, drake, drilling platform, drum, drumstick, dugong, dumbbell, dung beetle, Dungeness crab, Dutch oven, ear, earthstar, echidna, eel, eft, eggnog, Egyptian cat, electric fan, electric guitar, electric locomotive, electric ray, English foxhound, English setter, English springer, entertainment center, EntleBucher, envelope, Eskimo dog, espresso, espresso maker, European fire salamander, European gallinule, face powder, feather boa, fiddler crab, fig, file, fire engine, fire screen, fireboat, flagpole, flamingo, flat-coated retriever, flatworm, flute, fly, folding chair, football helmet, forklift, fountain, fountain pen, four-poster, fox squirrel, freight car, French bulldog, French horn, French loaf, frilled lizard, frying pan, fur coat, gar, garbage truck, garden spider, garter snake, gas pump, gasmask, gazelle, German shepherd, German short-haired pointer, geyser, giant panda, giant schnauzer, gibbon, Gila monster, go-kart, goblet, golden retriever, goldfinch, goldfish, golf cart, gondola, gong, goose, Gordon setter, gorilla, gown, grand piano, Granny Smith, grasshopper, Great Dane, great grey owl, Great Pyrenees, great white shark,

More Finegrained Classes

PASCAL

birds



bird

cats



cat

dogs



dog

ILSVRC

flamingo



cock



ruffed grouse



quail



partridge



...

Egyptian cat



Persian cat



Siamese cat



tabby



lynx



...

dalmatian



keeshond



miniature schnauzer



standard schnauzer



giant schnauzer



...

Quirks and Limitations of the Data Set



- Generated from WordNet ontology
 - Some animal categories are overrepresented
 - E.g., 120 subcategories of dog breeds
- ⇒ 6.7% top-5 error looks all the more impressive

Topics of This Lecture

- Recap: CNNs
- CNN Architectures
 - LeNet
 - AlexNet
 - VGGNet
 - GoogLeNet
 - ResNets
- **Visualizing CNNs**
 - Visualizing CNN features
 - Visualizing responses
 - Visualizing learned structures
- Applications

Visualizing CNNs

DeconvNet

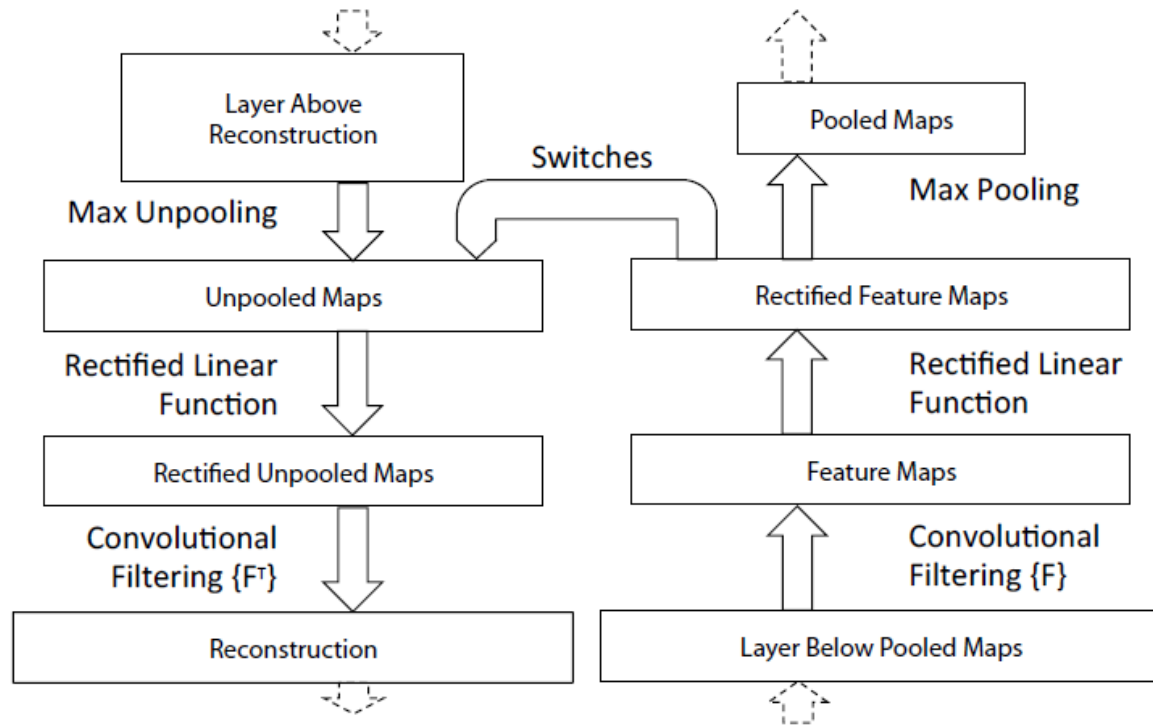

ConvNet

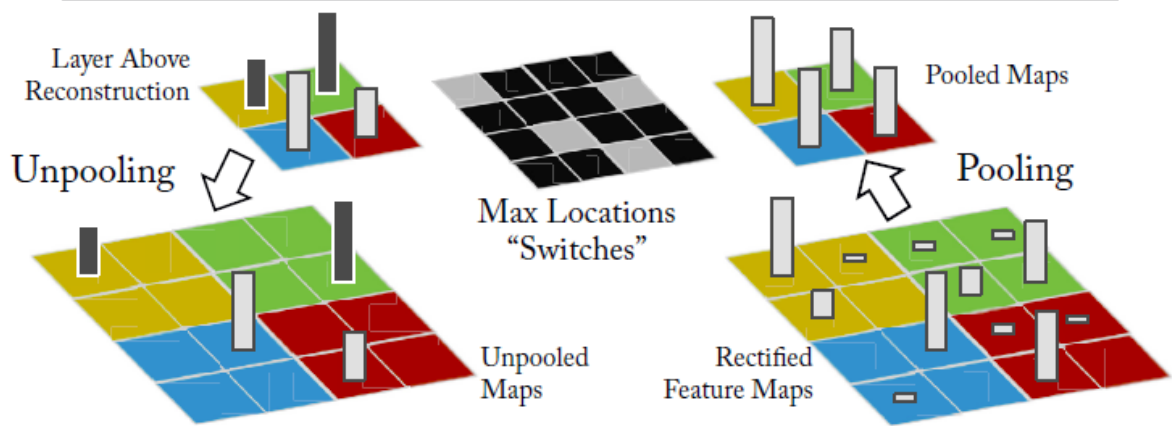

Visualizing CNNs

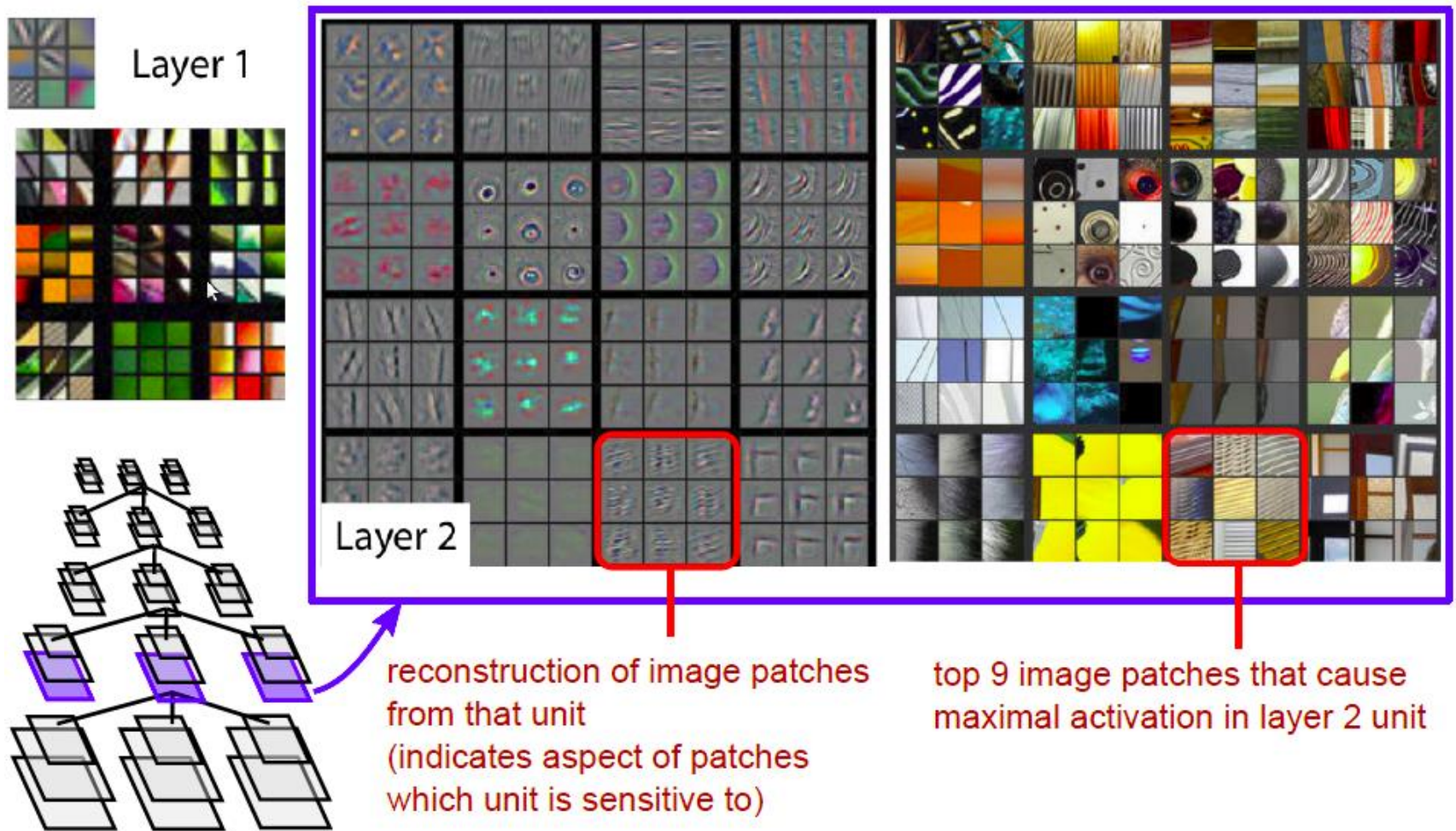

M. Zeiler, R. Fergus, [Visualizing and Understanding Convolutional Neural Networks](#), ECCV 2014.

Visualizing CNNs

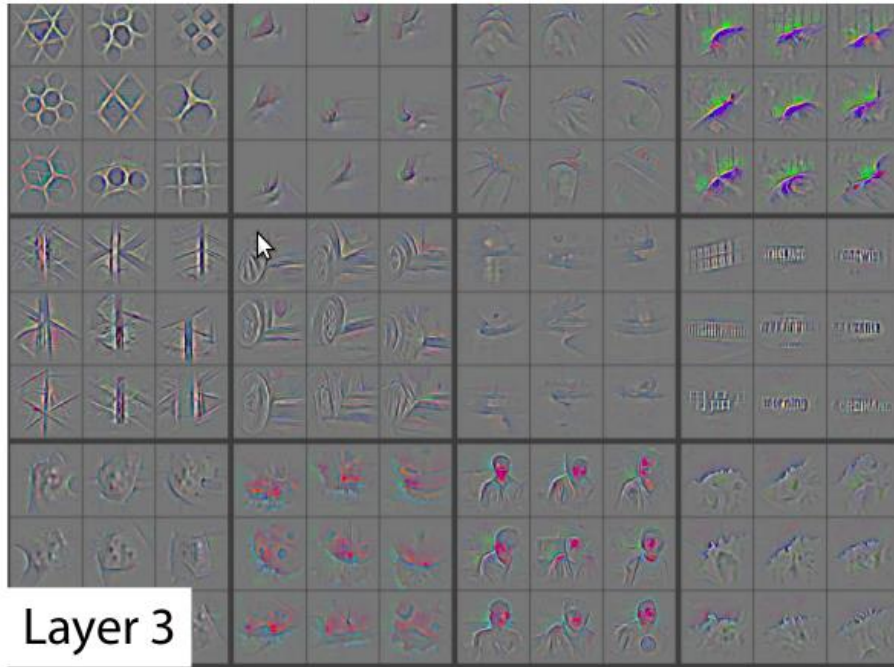

Visualizing CNNs

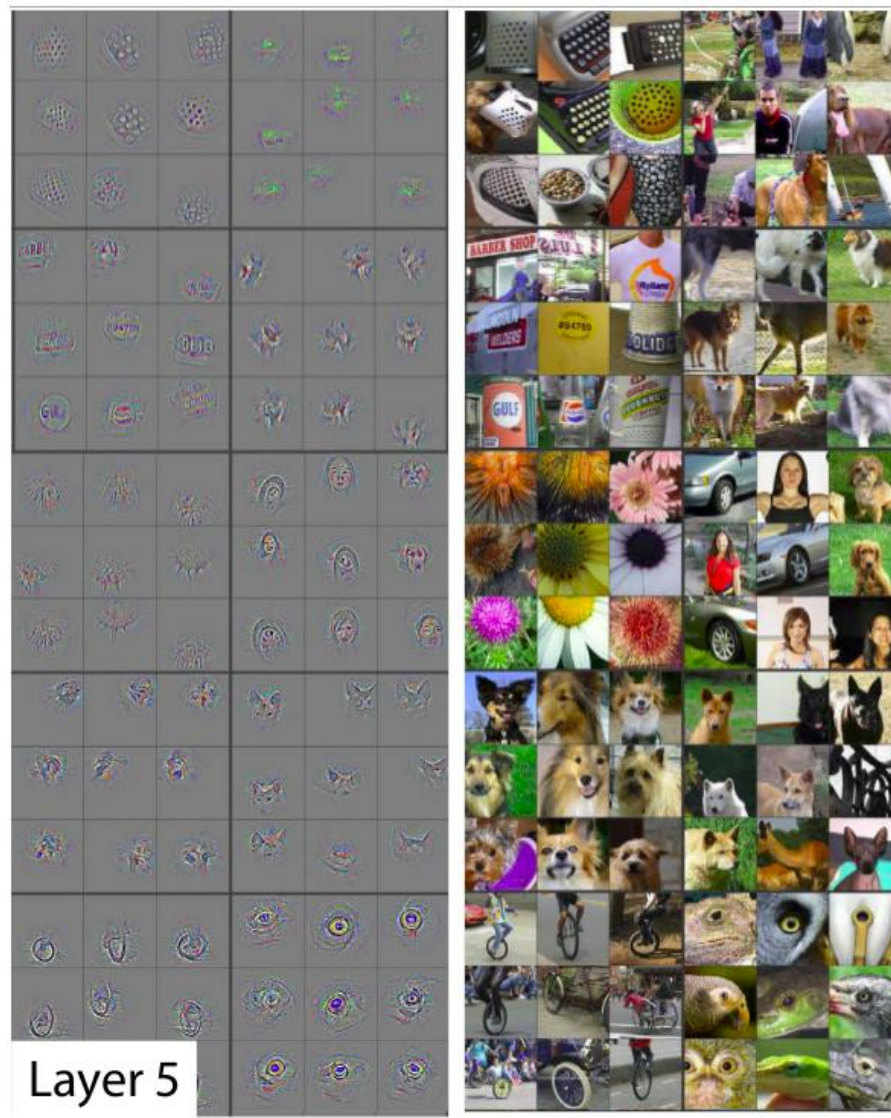
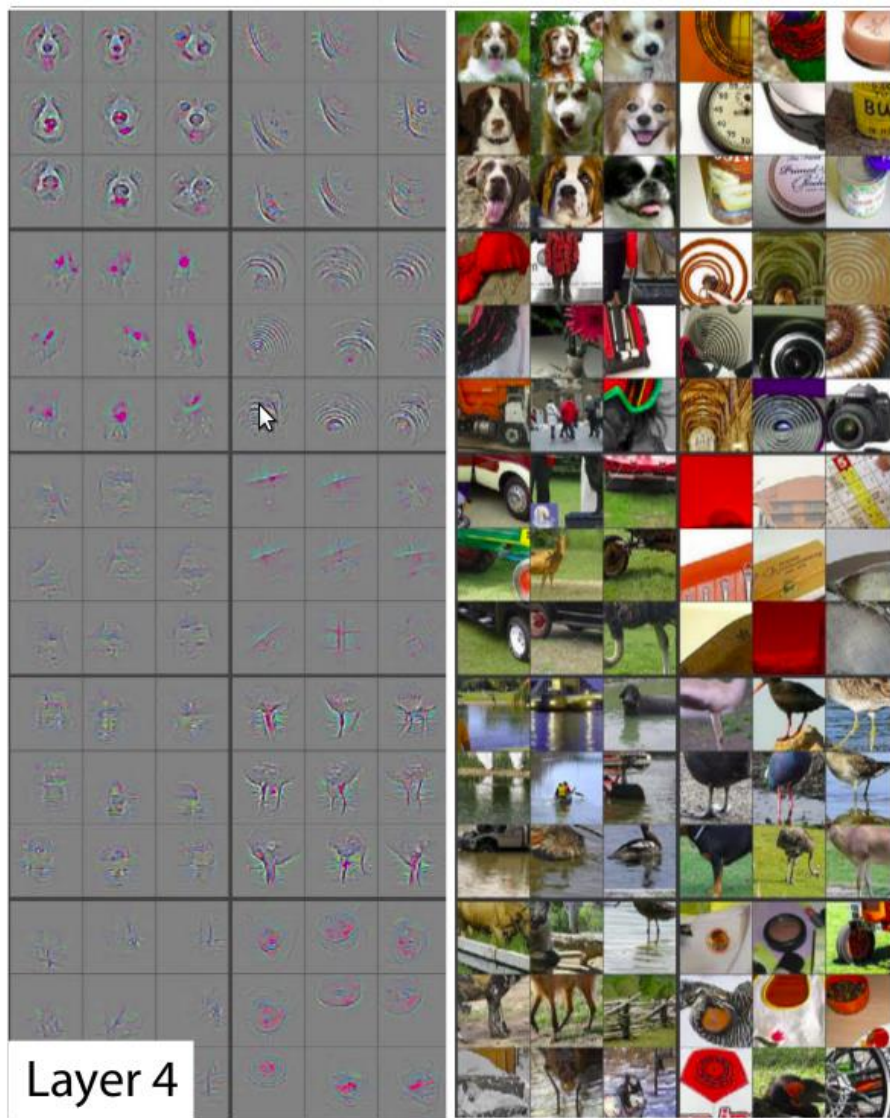

What Does the Network React To?

- Occlusion Experiment
 - Mask part of the image with an occluding square.
 - Monitor the output



What Does the Network React To?

Input image



$p(\text{True class})$

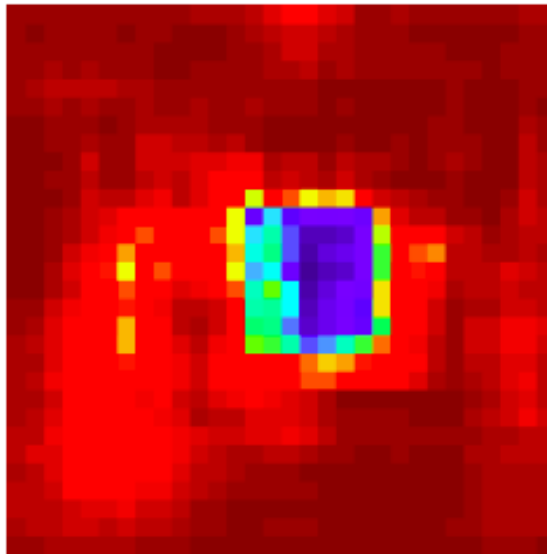

Most probable class

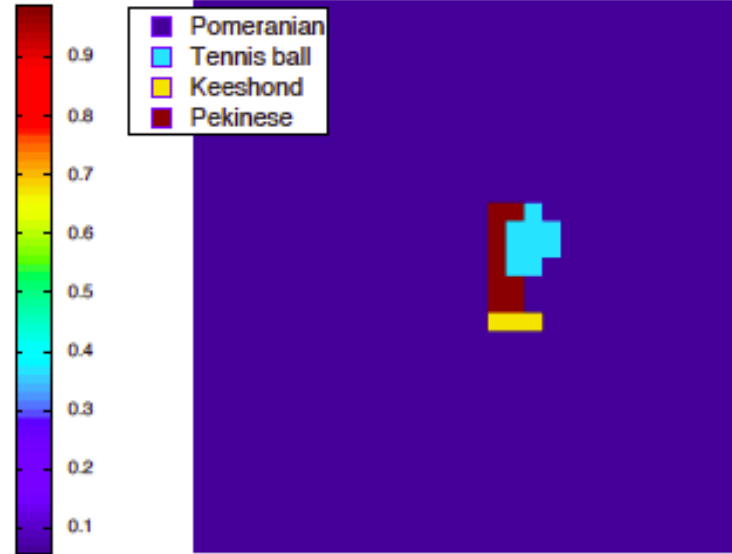

What Does the Network React To?

Input image



Total activation in most active 5th layer feature map

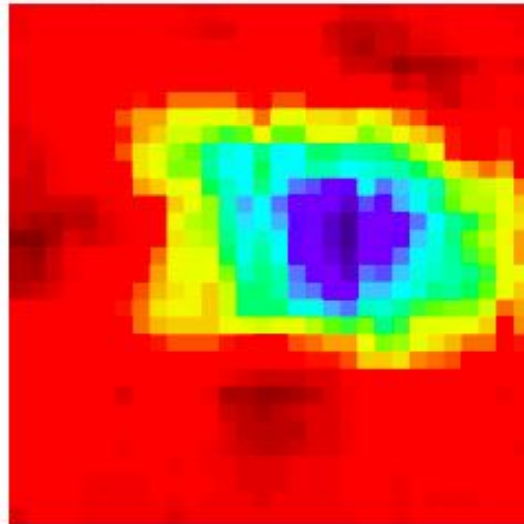

Other activations from the same feature map.

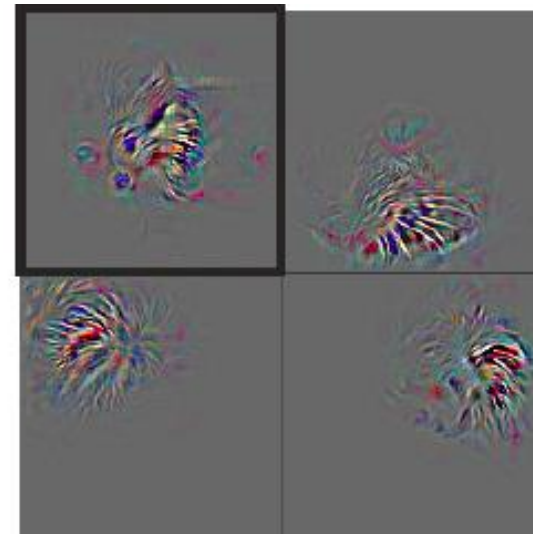

What Does the Network React To?

Input image



$p(\text{True class})$

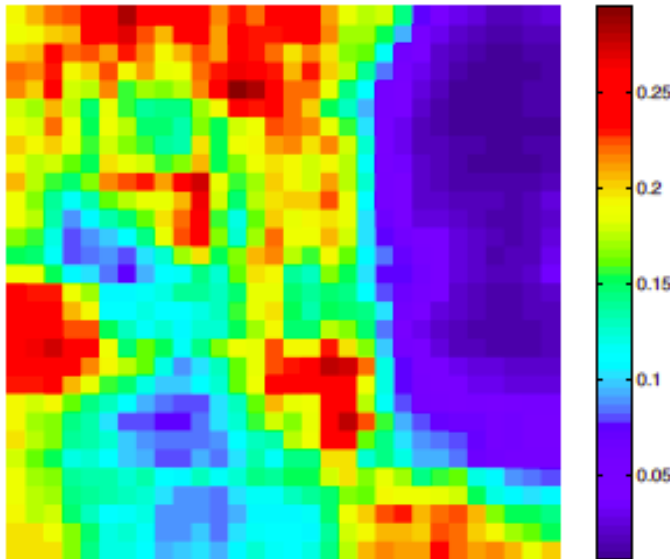

Most probable class

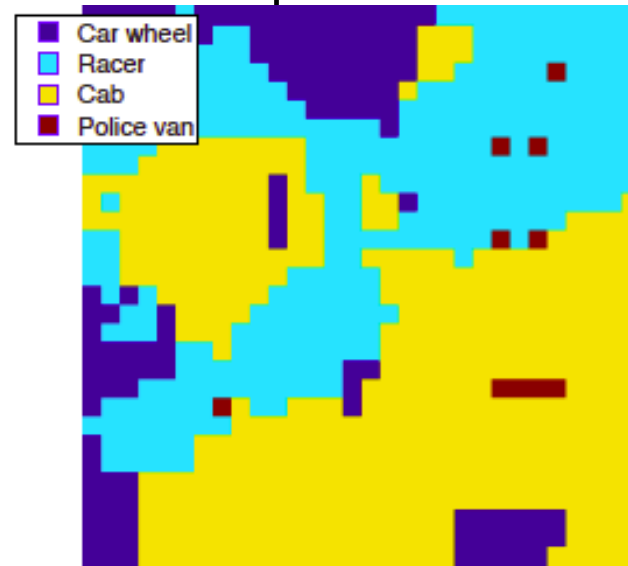

What Does the Network React To?

Input image



Total activation in most active 5th layer feature map

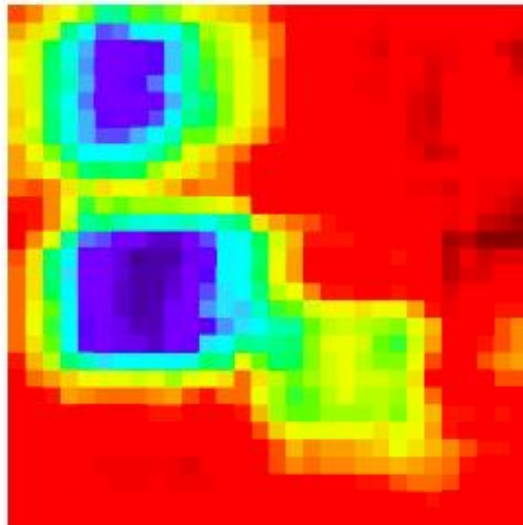

Other activations from the same feature map.



What Does the Network React To?

Input image

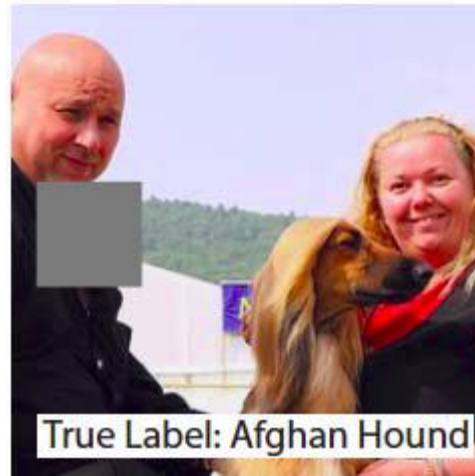

$p(\text{True class})$

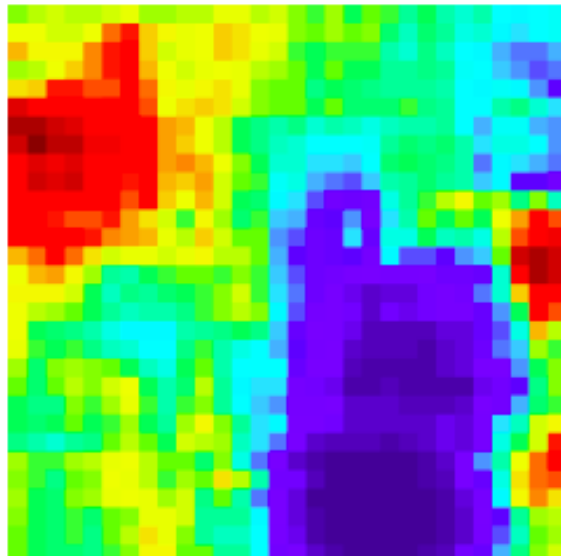

Most probable class

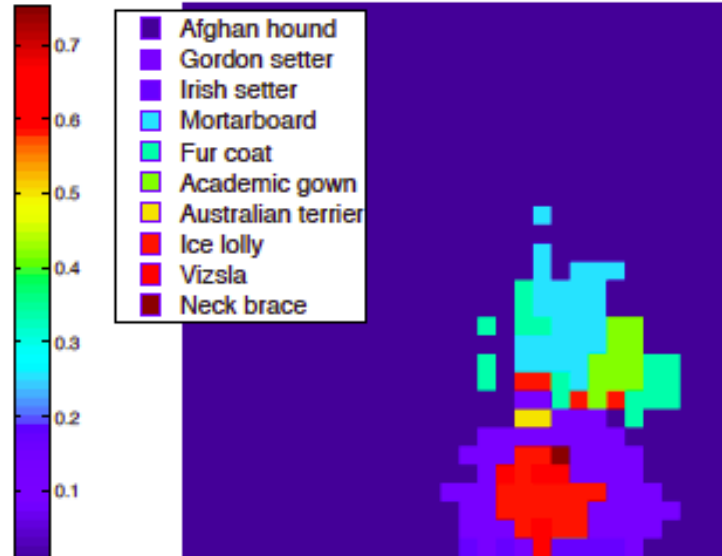

What Does the Network React To?

Input image

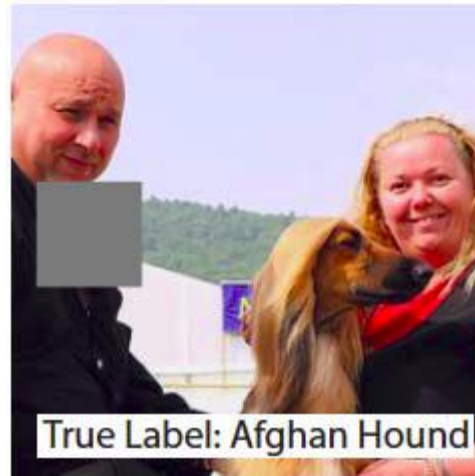

Total activation in most active 5th layer feature map

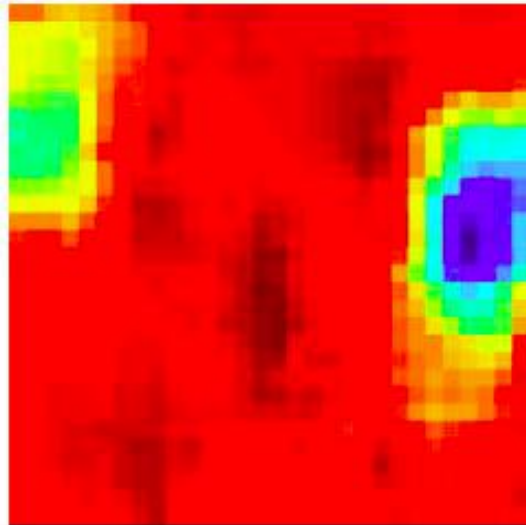

Other activations from the same feature map.



Inceptionism: Dreaming ConvNets

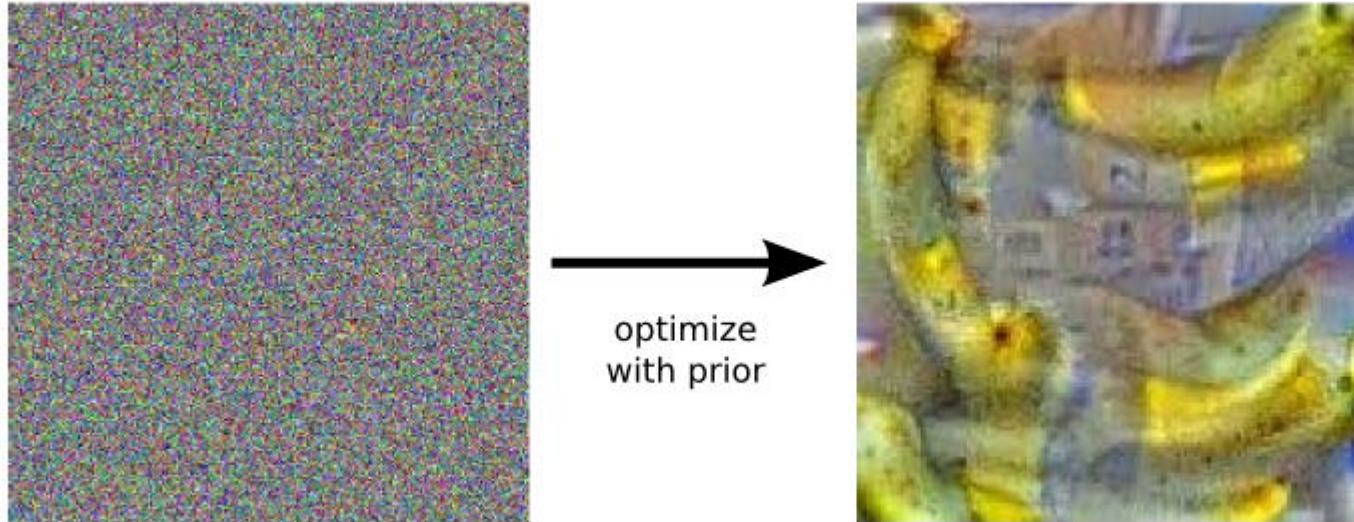

- Idea

- Start with a random noise image.
 - Enhance the input image such as to enforce a particular response (e.g., banana).
 - Combine with prior constraint that image should have similar statistics as natural images.
- ⇒ Network hallucinates characteristics of the learned class.

Inceptionism: Dreaming ConvNets

- Results



Inceptionism: Dreaming ConvNets

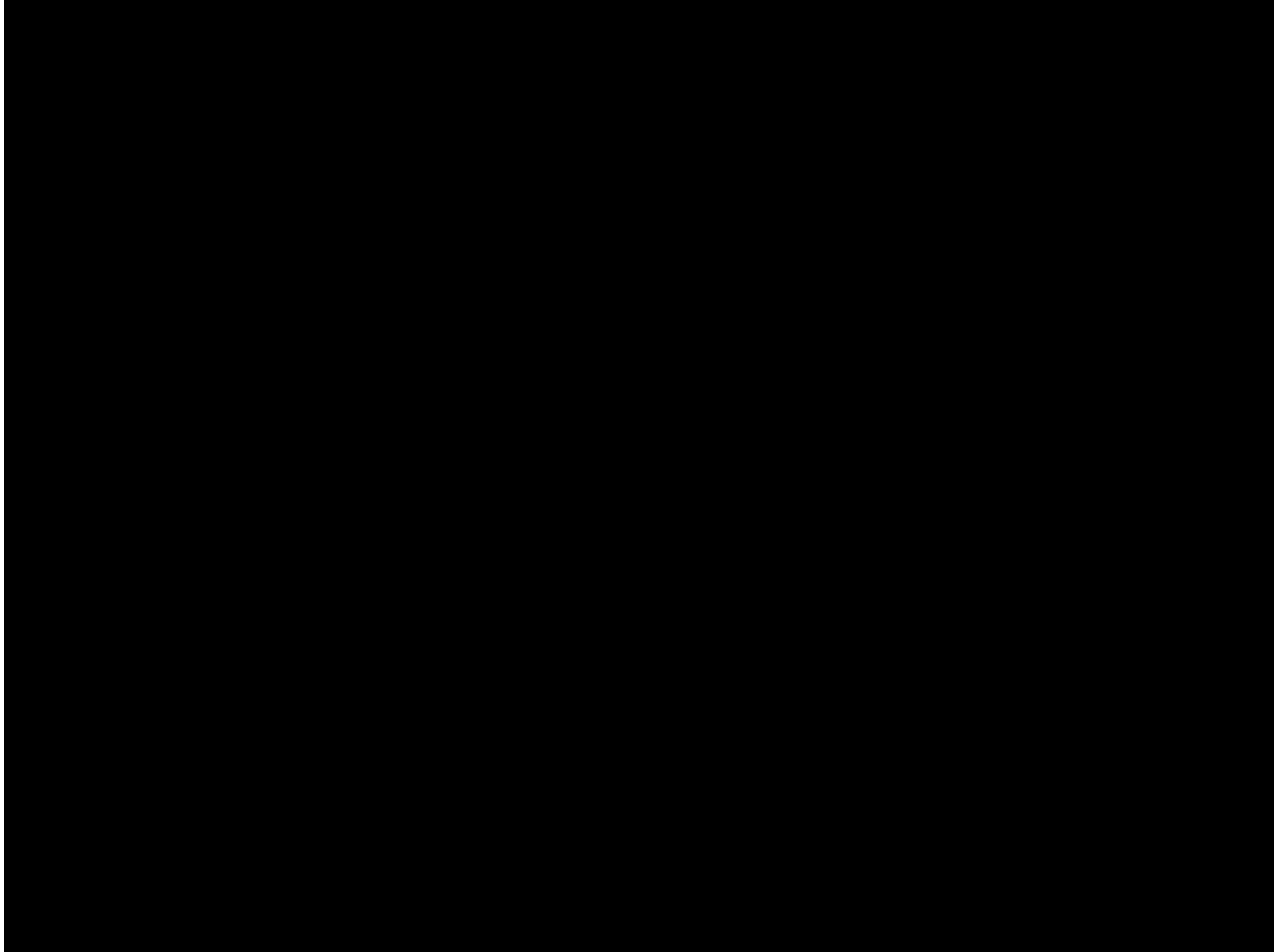

<https://www.youtube.com/watch?v=IREsx-xWQ0g>

Topics of This Lecture

- Recap: CNNs
- CNN Architectures
 - LeNet
 - AlexNet
 - VGGNet
 - GoogLeNet
 - ResNets
- Visualizing CNNs
 - Visualizing CNN features
 - Visualizing responses
 - Visualizing learned structures
- Applications

The Learned Features are Generic

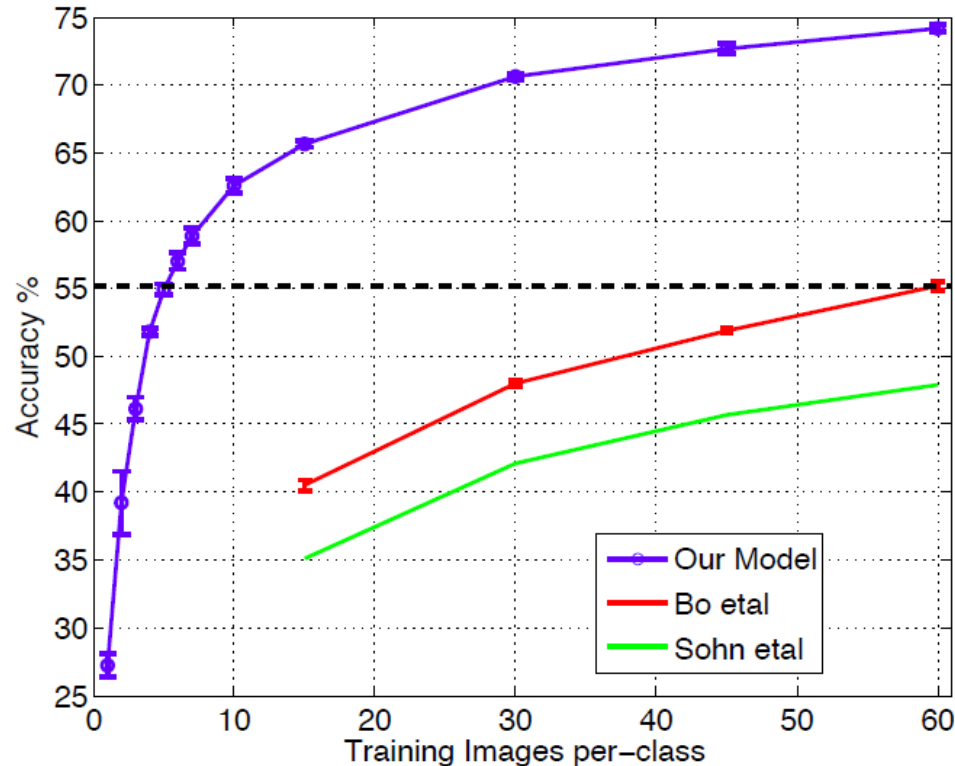

state of the art
level (pre-CNN)

- Experiment: feature transfer
 - Train network on ImageNet
 - Chop off last layer and train classification layer on CalTech256⇒ State of the art accuracy already with only 6 training images

Transfer Learning with CNNs



1. Train on ImageNet



2. If small dataset: fix all weights (treat CNN as fixed feature extractor), retrain only the classifier

I.e., swap the Softmax layer at the end

Transfer Learning with CNNs



1. Train on ImageNet

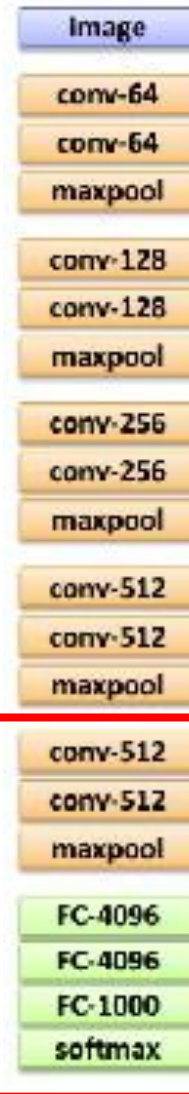

3. If you have medium sized dataset, “**finetune**” instead: use the old weights as initialization, train the full network or only some of the higher layers.

Retrain bigger portion of the network



Other Tasks: Detection

R-CNN: *Regions with CNN features*

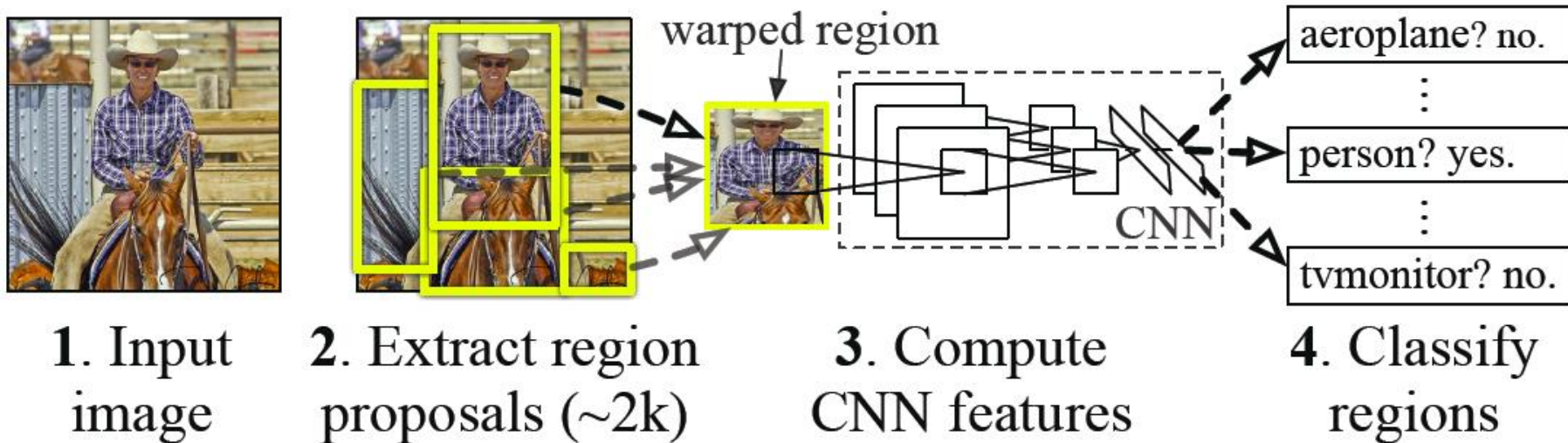

- Results on PASCAL VOC Detection benchmark
 - Pre-CNN state of the art: 35.1% mAP [Uijlings et al., 2013]
 - DPM: 33.4% mAP
 - R-CNN: 53.7% mAP

R. Girshick, J. Donahue, T. Darrell, and J. Malik, [Rich Feature Hierarchies for Accurate Object Detection and Semantic Segmentation](#), CVPR 2014

Most Recent Version: Faster R-CNN

- One network, four losses

- Remove dependence on external region proposal algorithm.

- Instead, infer region proposals from same CNN.
 - Feature sharing
 - Joint training
- ⇒ Object detection in a single pass becomes possible.
- ⇒ mAP improved to >70%

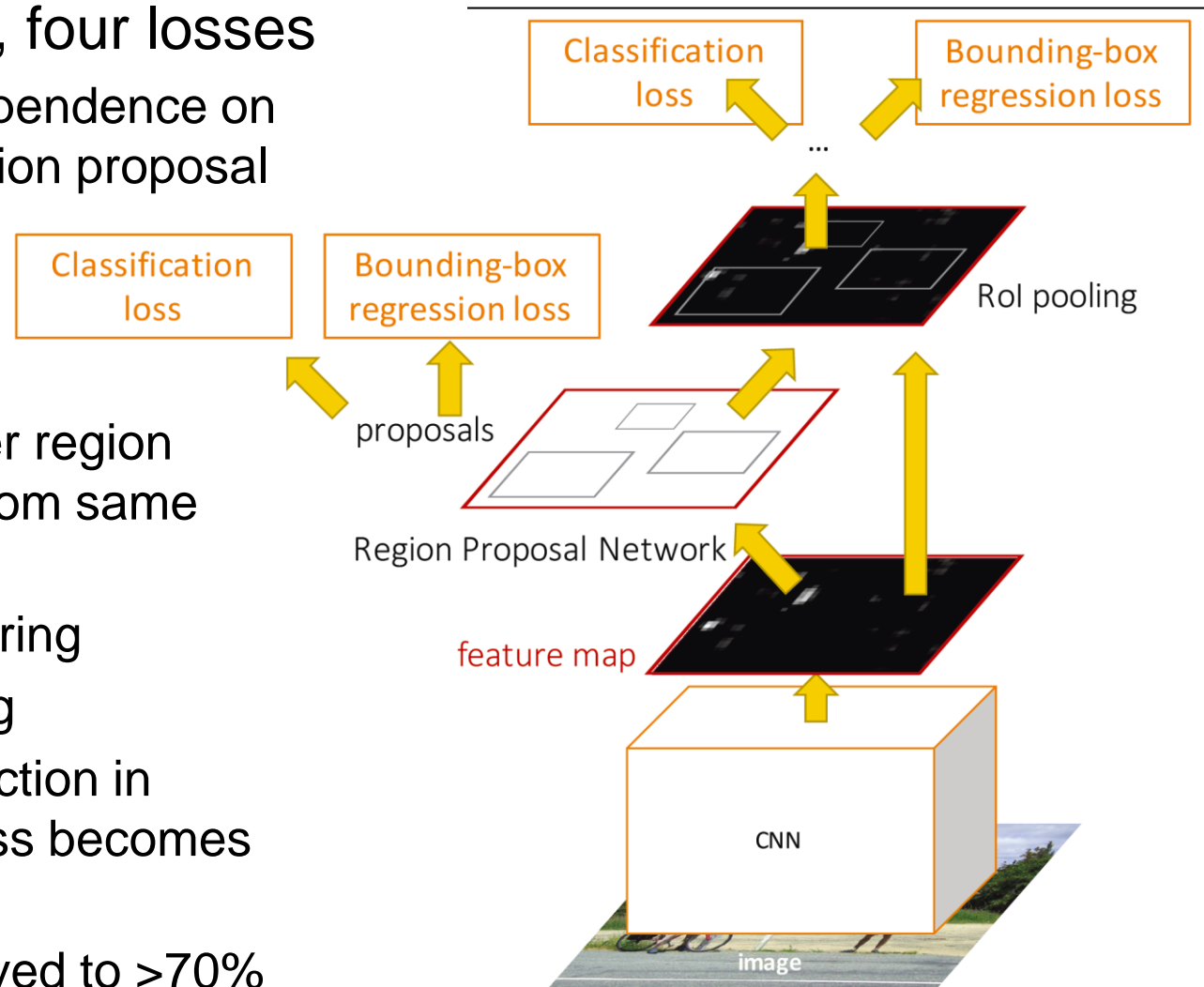

Faster R-CNN (based on ResNets)

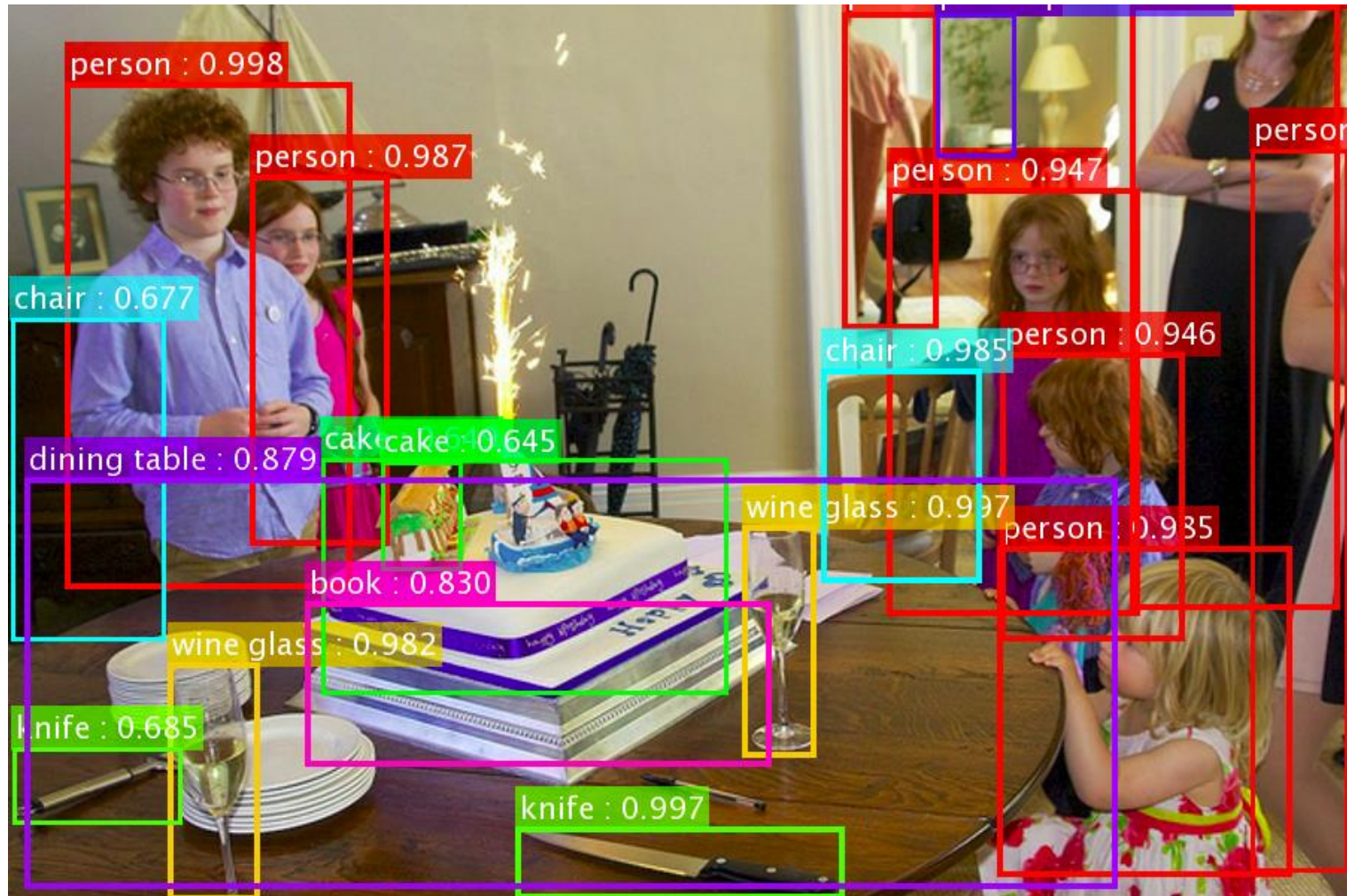

K. He, X. Zhang, S. Ren, J. Sun, [Deep Residual Learning for Image Recognition](#), CVPR 2016.

Faster R-CNN (based on ResNets)

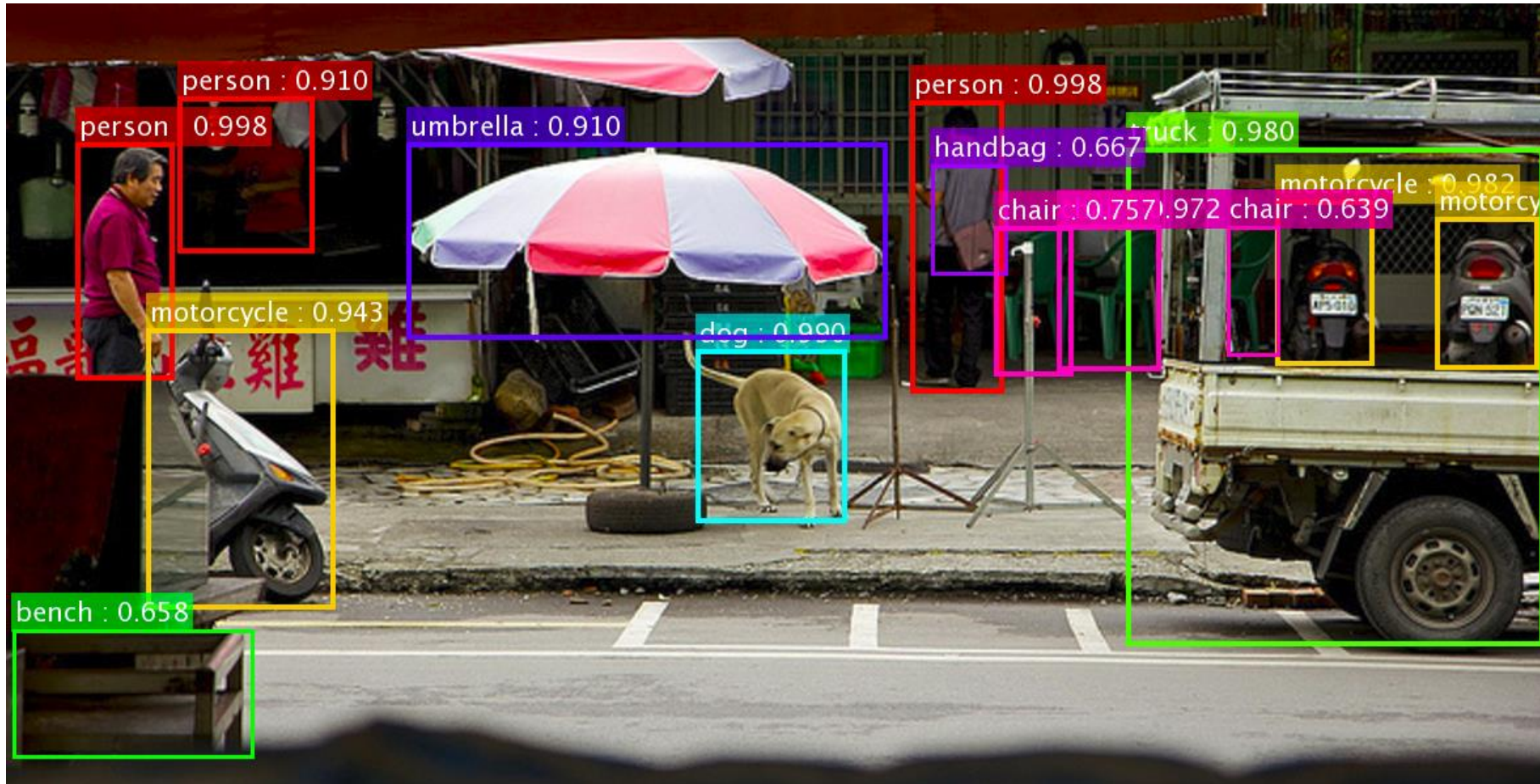

K. He, X. Zhang, S. Ren, J. Sun, [Deep Residual Learning for Image Recognition](#), CVPR 2016.

Object Detection Performance

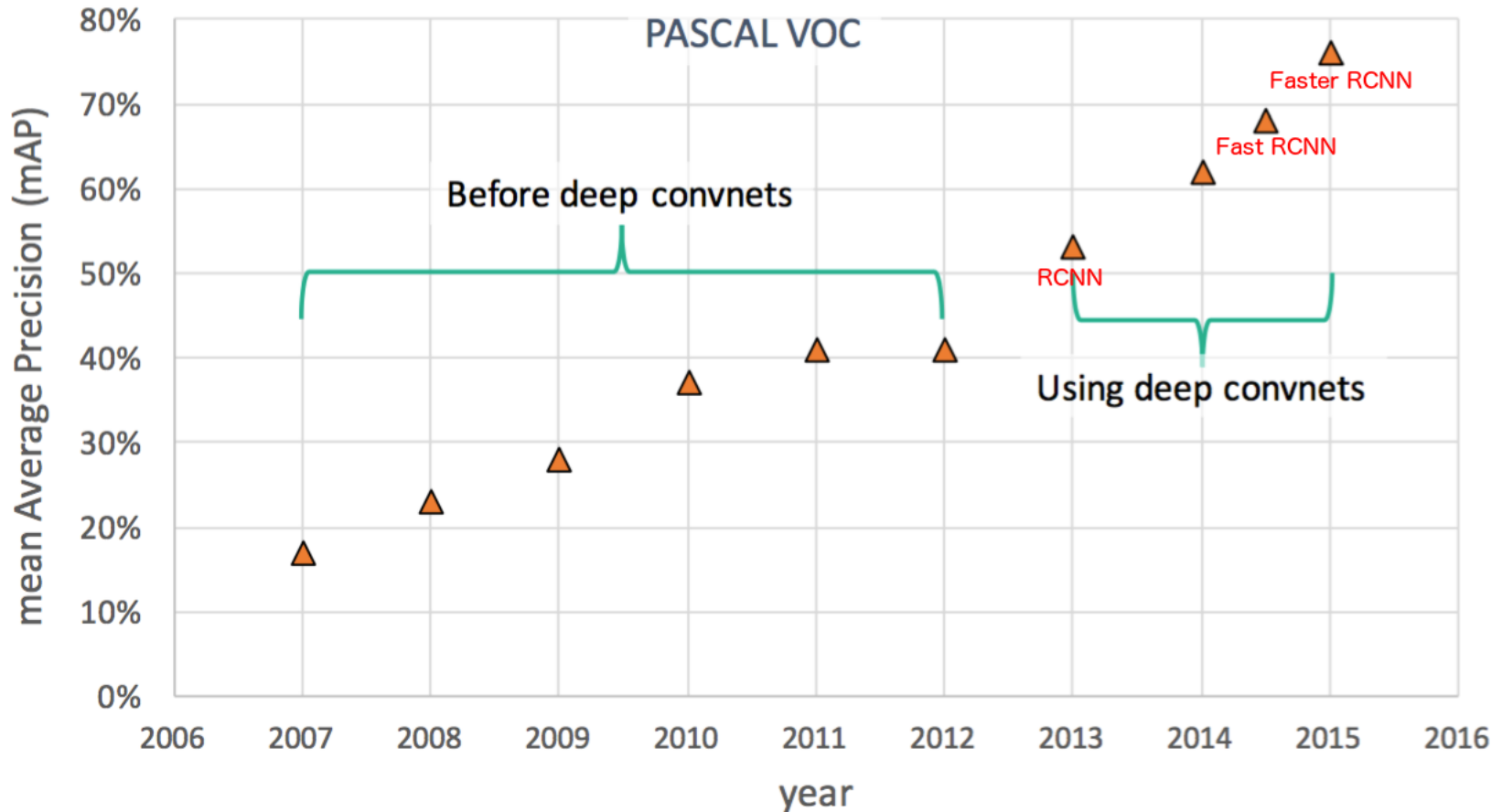

PASCAL VOC Object Detection Performance

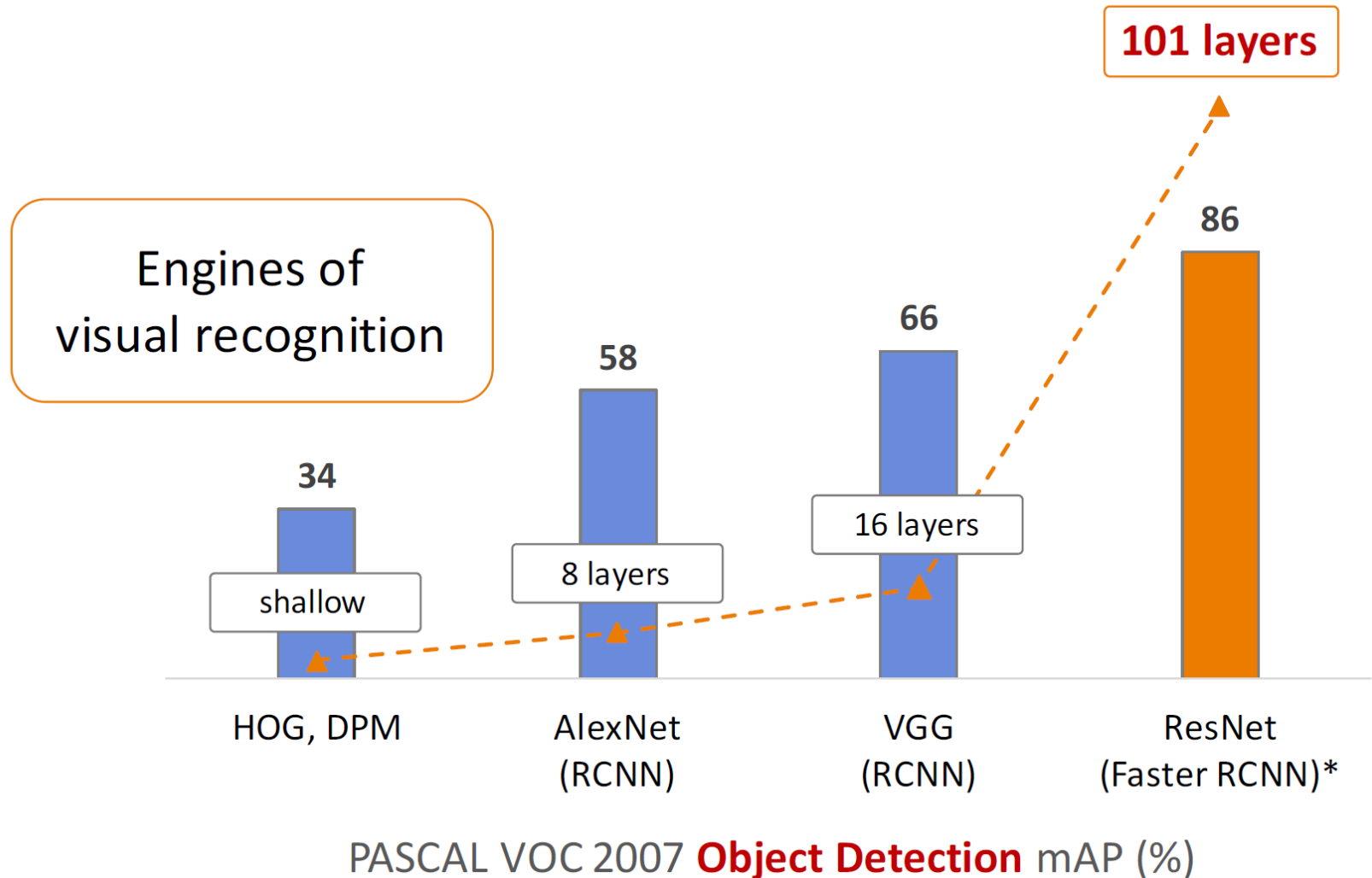

Most Recent Version: Mask R-CNN

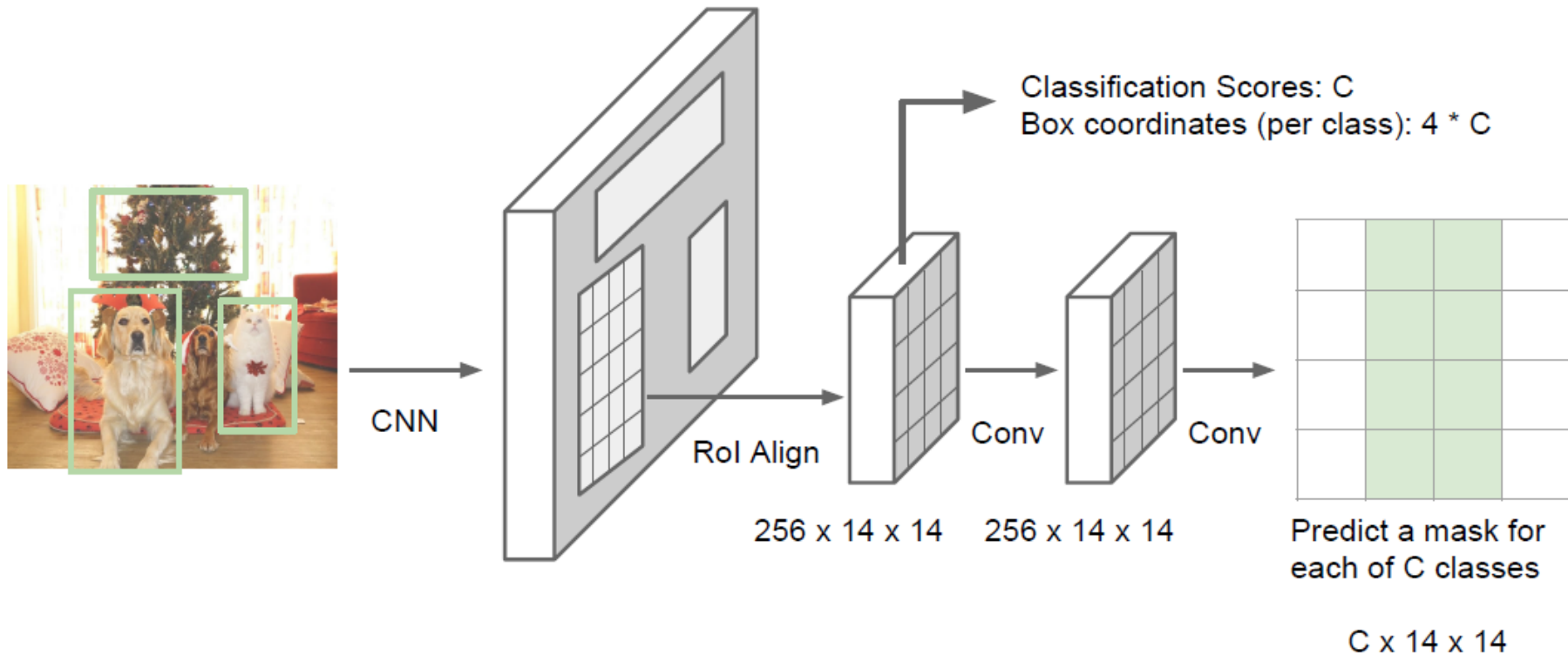

K. He, G. Gkioxari, P. Dollar, R. Girshick, [Mask R-CNN](#), arXiv 1703.06870.

Mask R-CNN Results

- Detection + Instance segmentation

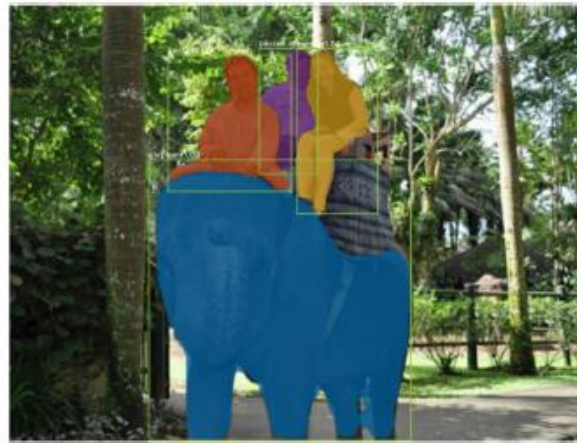

- Detection + Pose estimation

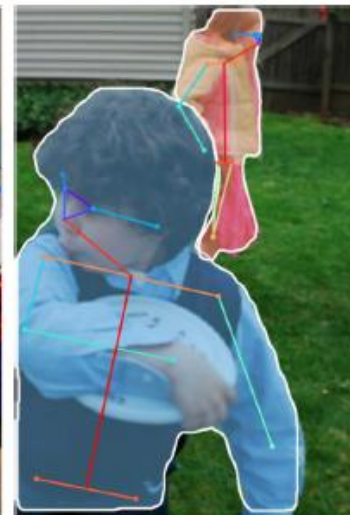
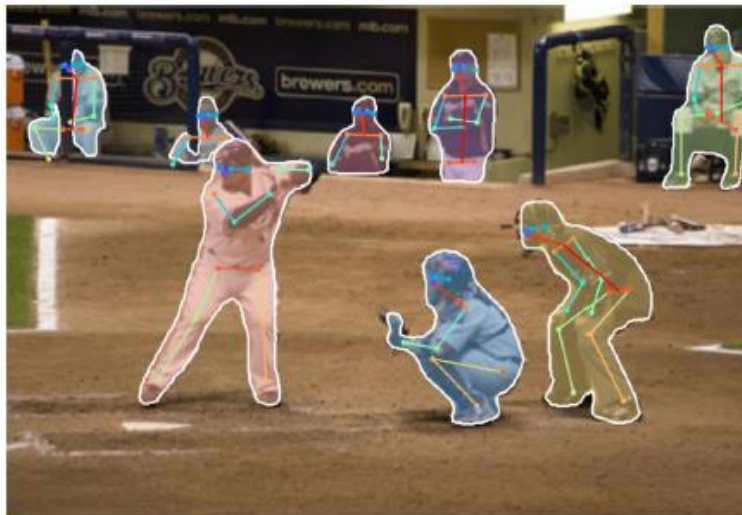
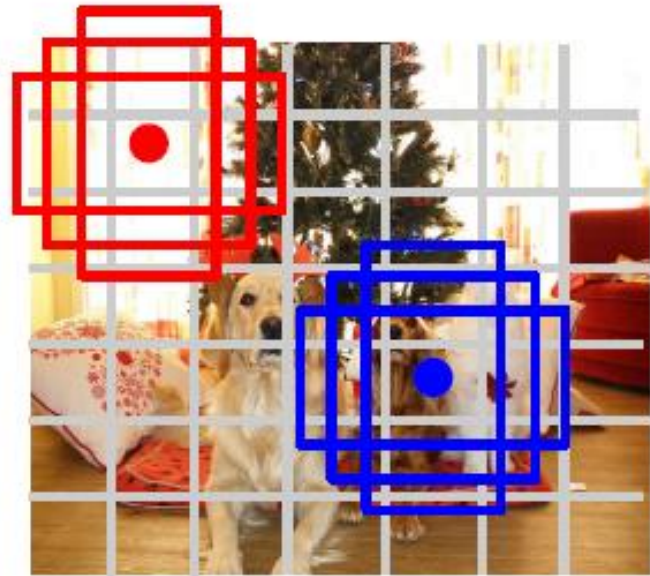

Figure credit: K. He, G. Gkioxari, P. Dollar, R. Girshick

YOLO / SSD



Input image
 $3 \times H \times W$



Divide image into grid
 7×7

- Idea: Directly go from image to detection scores
- Within each grid cell
 - Start from a set of anchor boxes
 - Regress from each of the B anchor boxes to a final box
 - Predict scores for each of C classes (including background)

YOLO-v3 Results

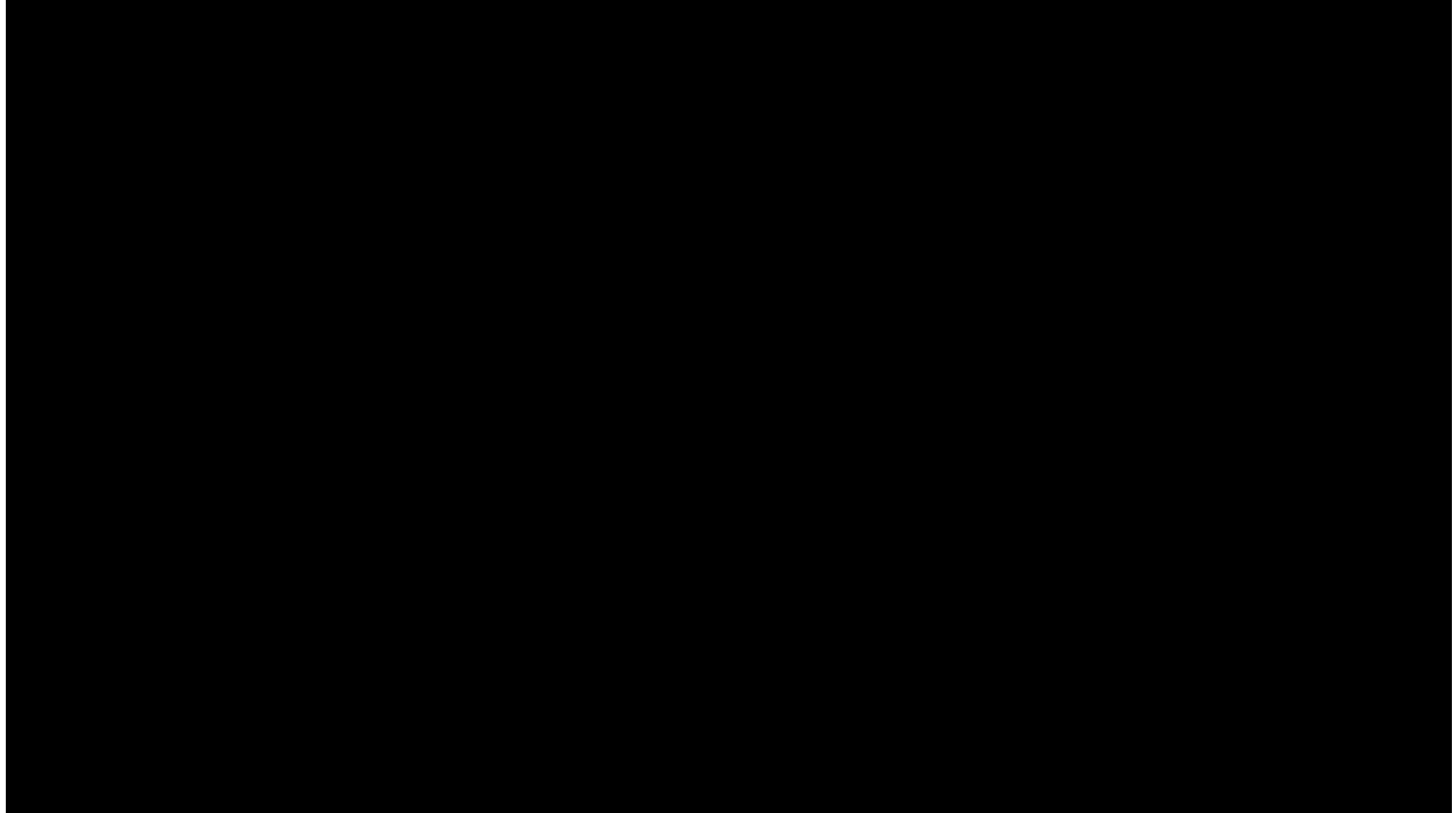

J. Redmon, S. Divvala, R. Girshick, A. Farhadi, [You Only Look Once: Unified, Real-Time Object Detection](#), CVPR 2016.

Semantic Image Segmentation

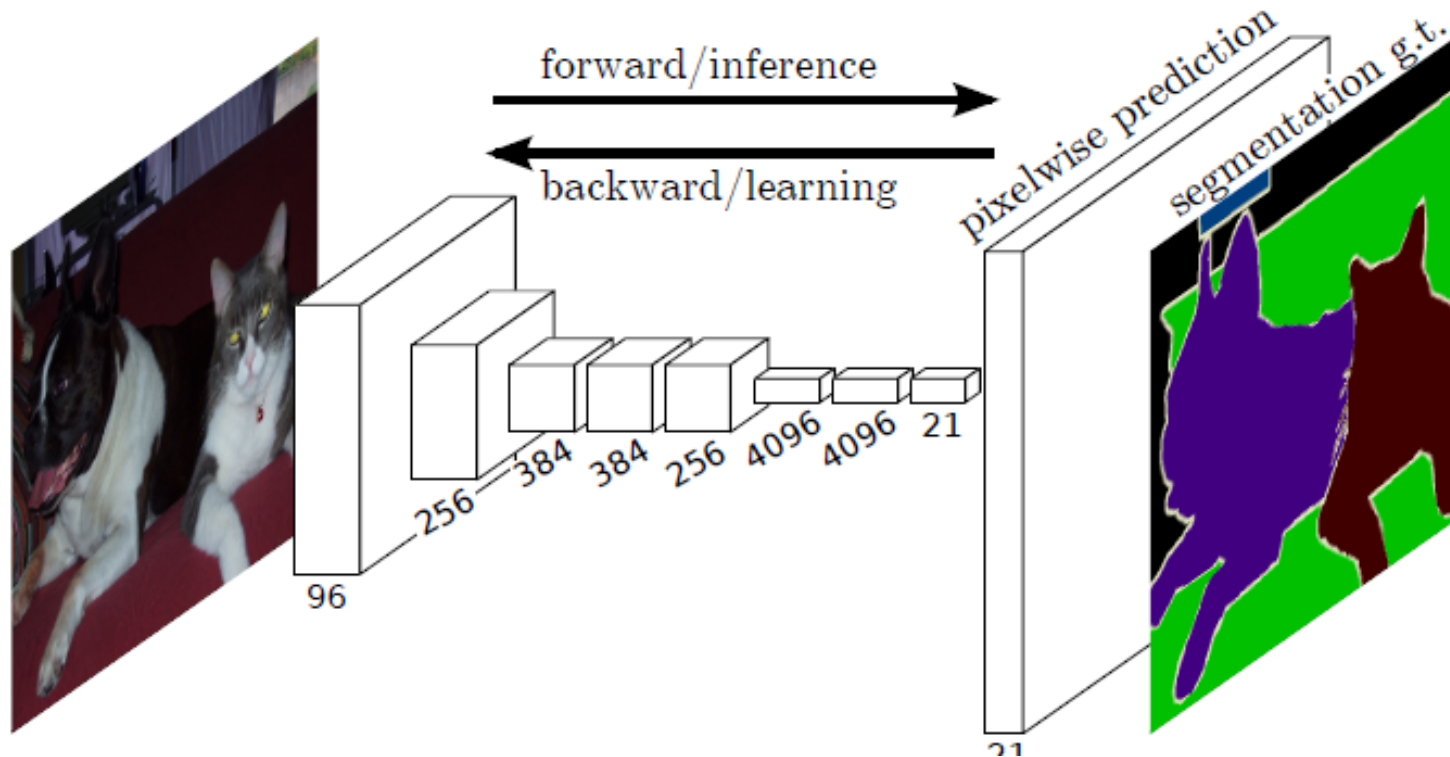

- Perform pixel-wise prediction task
 - Usually done using **Fully Convolutional Networks (FCNs)**
 - All operations formulated as convolutions
 - Advantage: can process arbitrarily sized images

CNNs vs. FCNs

- CNN

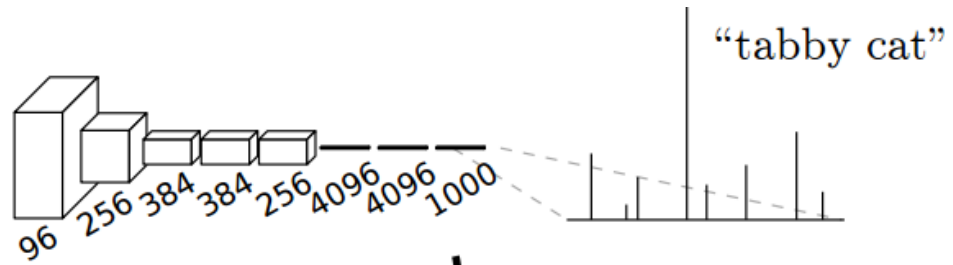

- FCN

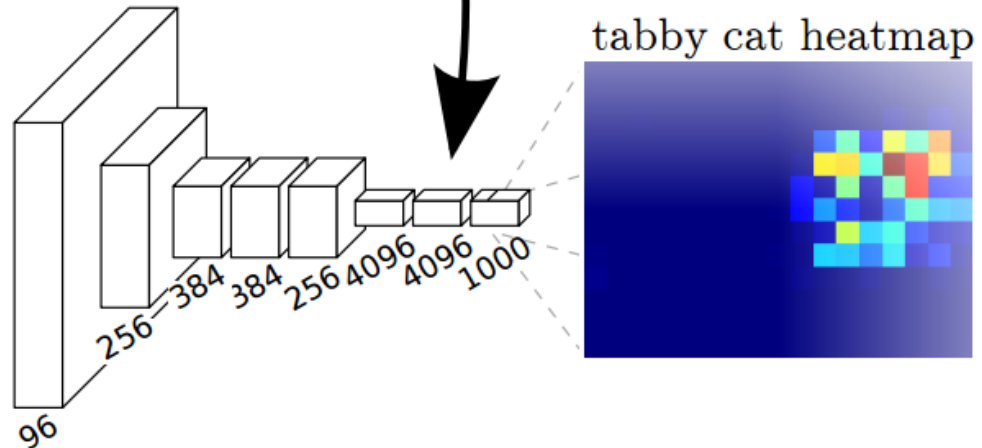

- Intuition

- Think of FCNs as performing a sliding-window classification, producing a heatmap of output scores for each class

Semantic Image Segmentation

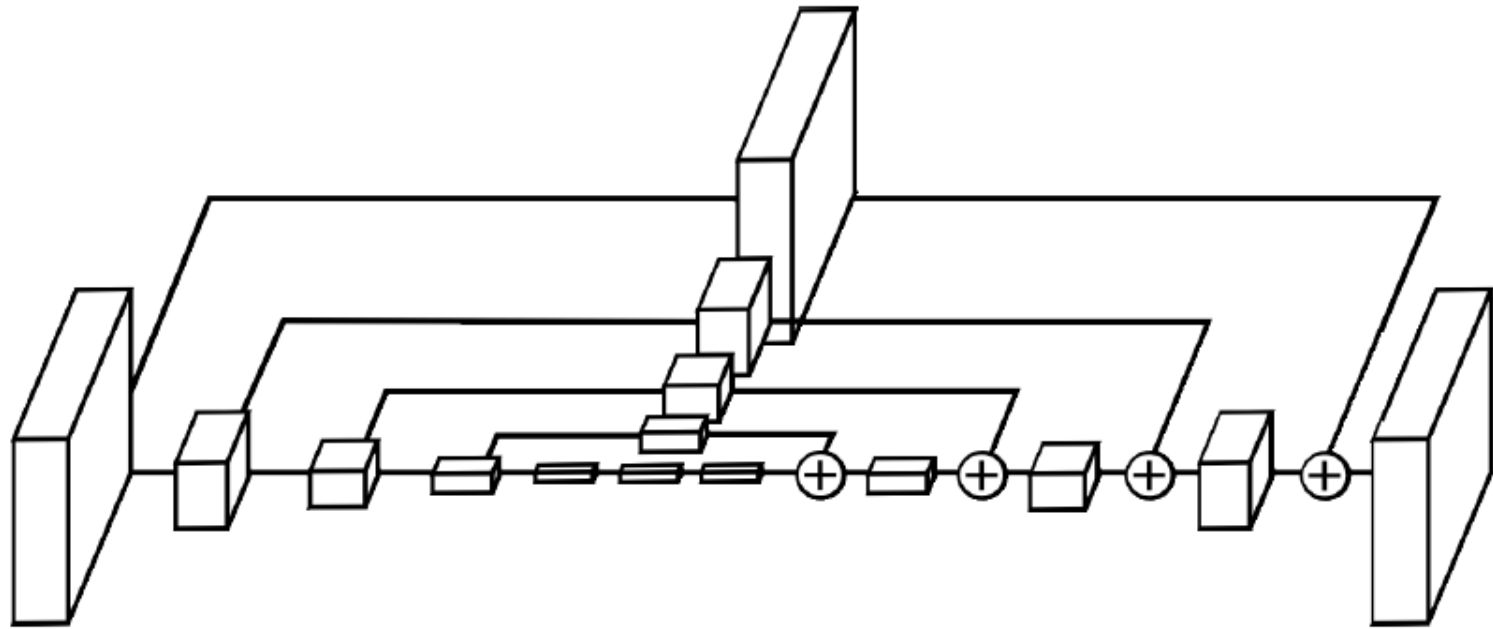

- Encoder-Decoder Architecture

- Problem: FCN output has low resolution
- Solution: perform upsampling to get back to desired resolution
- Use skip connections to preserve higher-resolution information

Semantic Segmentation



- Current state-of-the-art
 - Based on an extension of ResNets

Other Tasks: Face Verification

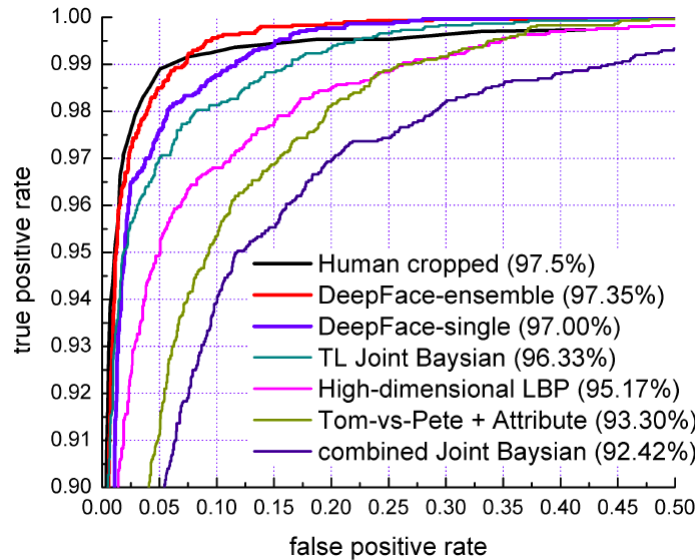
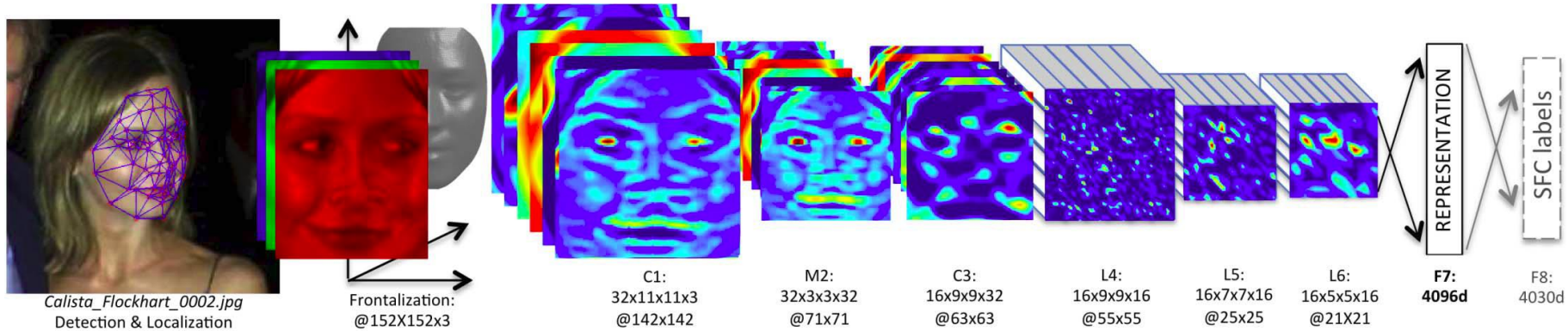

Y. Taigman, M. Yang, M. Ranzato, L. Wolf, [DeepFace: Closing the Gap to Human-Level Performance in Face Verification](#), CVPR 2014

Commercial Recognition Services

- E.g., **clarifai**



Try it out with your own media

Upload an image or video file under 100mb or give us a direct link to a file on the web.

Paste a url here... ENGLISH ▼

USE THE URL CHOOSE A FILE INSTEAD

*By using the demo you agree to our terms of service

- Be careful when taking test images from Google Search
 - Chances are they may have been seen in the training set...

References and Further Reading

- LeNet
 - Y. LeCun, L. Bottou, Y. Bengio, and P. Haffner, [Gradient-based learning applied to document recognition](#), Proceedings of the IEEE 86(11): 2278–2324, 1998.
- AlexNet
 - A. Krizhevsky, I. Sutskever, and G. Hinton, [ImageNet Classification with Deep Convolutional Neural Networks](#), NIPS 2012.
- VGGNet
 - K. Simonyan, A. Zisserman, [Very Deep Convolutional Networks for Large-Scale Image Recognition](#), ICLR 2015
- GoogLeNet
 - C. Szegedy, W. Liu, Y. Jia, et al, [Going Deeper with Convolutions](#), arXiv:1409.4842, 2014.

References and Further Reading

- ResNets

- K. He, X. Zhang, S. Ren, J. Sun, [Deep Residual Learning for Image Recognition](#), CVPR 2016.
- A. Veit, M. Wilber, S. Belongie, [Residual Networks Behave Like Ensembles of Relatively Shallow Networks](#), NIPS 2016.

References: Computer Vision Tasks

- Object Detection

- R. Girshick, J. Donahue, T. Darrell, J. Malik, Rich Feature Hierarchies for Accurate Object Detection and Semantic Segmentation, CVPR 2014.
- S. Ren, K. He, R. Girshick, J. Sun, Faster R-CNN: Towards Real-Time Object Detection with Region Proposal Networks, NIPS 2015.
- J. Redmon, S. Divvala, R. Girshick, A. Farhadi, You Only Look Once: Unified Real-Time Object Detection, CVPR 2016.
- W. Liu, D. Anguelov, [D. Erhan](#), [C. Szegedy](#), S. Reed, C-Y. Fu, A.C. Berg, SSD: Single Shot Multi Box Detector, ECCV 2016.

References: Computer Vision Tasks

- Semantic Segmentation

- J. Long, E. Shelhamer, T. Darrell, Fully Convolutional Networks for Semantic Segmentation, CVPR 2015.
- H. Zhao, J. Shi, X. Qi, X. Wang, J. Jia, Pyramid Scene Parsing Network, arXiv 1612.01105, 2016.